

ORDINANCE

CITY OF NEW ORLEANS

CITY HALL: April 9, 2026

CALENDAR NO. 35,414

NO. _____ MAYOR COUNCIL SERIES

BY: COUNCILMEMBER HARRIS (BY REQUEST)

AN ORDINANCE to authorize the Mayor of the City of New Orleans to enter into a Cooperative Endeavor Agreement, Lease of Land, and Act of Donation between the City of New Orleans (the “City”) and Mercy Partners, LLC (“Mercy Partners”), for the public purpose of constructing water retention infrastructure at the site formerly known as Lindy Boggs Medical Center (the “Site”) for the benefit of the water, sewer, and drainage infrastructure for the City of New Orleans, and in turn the health, welfare, and safety of the citizens in the City of New Orleans, and related activities, as more fully detailed in the Cooperative Endeavor Agreement form attached hereto as Exhibit “A”, the Lease of Land form attached hereto as Exhibit “B”, and the Act of Donation form attached hereto as Exhibit “C”; and otherwise to provide with respect thereto.

WHEREAS, pursuant to the authority contained in Article 7, Section 14(C) of the Louisiana Constitution of 1974, and statutory authority supplemental thereto, the State of Louisiana and its political subdivisions, including the City, may enter into cooperative endeavors with each other, or with any public or private corporation or individual; and further pursuant to Section 9-314 of the Home Rule Charter of the City of New Orleans, the City may enter into cooperative endeavors with any public or private association, corporation, or individual for activities in support of economic growth and other public purposes; and

WHEREAS, the City and Mercy Partners desire to accomplish the valuable public purpose of constructing a water retention control structure and system on the Site, which will include an underground water retention tank and inflow and outflow structures that connect to the existing public

drainage system within the nearby public right of way (collectively, the “Project”); and

WHEREAS, on November 15, 2025, pursuant to Resolution No. R-25-427, a majority of the electors of the City authorized the issuance of up to \$415 million in general obligation bonds for the purpose of making capital improvements in the City (the “Approved Bonds”); and

WHEREAS, the City desires to use a portion of the proceeds of the Approved Bonds to fund a portion of the Project, to include demolition of the existing on-site structures and construction of the water retention infrastructure; and

WHEREAS, following construction of the Project, Mercy Partners will lease to the City the portions of the Project located on the Site, on the terms and conditions described in the Lease of Land; and

WHEREAS, following construction of the Project, Mercy Partners will donate to the City for the use and benefit of the Sewerage and Water Board of New Orleans the portions of the Project located within the public right of way, on the terms and conditions described in the Act of Donation;

NOW, THEREFORE

1 **SECTION 1. THE COUNCIL OF THE CITY OF NEW ORLEANS HEREBY**
2 **ORDAINS**, That the Mayor, on behalf of the City of New Orleans, is hereby authorized to enter into
3 the attached Cooperative Endeavor Agreement with Mercy Partners, LLC, for a term of greater than
4 one year, for the public purpose of constructing water retention infrastructure at the site formerly
5 known as Lindy Boggs Medical Center for the benefit of the water, sewer, and drainage infrastructure
6 for the City of New Orleans, and in turn the health, welfare, and safety of the citizens in the City of
7 New Orleans.

1 **SECTION 2.** That said Cooperative Endeavor Agreement is attached to this ordinance as
2 Exhibit “A” and incorporated herein and made a part hereof.

1 **SECTION 3.** That the Mayor, on behalf of the City of New Orleans, is hereby authorized to

2 enter into the attached Lease of Land with Mercy Partners, LLC, for a term of greater than one year,
3 for the public purpose of constructing water retention infrastructure at the site formerly known as Lindy
4 Boggs Medical Center for the benefit of the water, sewer, and drainage infrastructure for the City of
5 New Orleans, and in turn the health, welfare, and safety of the citizens in the City of New Orleans.

1 **SECTION 4.** That said Lease of Land is attached to this ordinance as Exhibit “B” and
2 incorporated herein and made a part hereof.

1 **SECTION 5.** That the Mayor, on behalf of the City of New Orleans, is hereby authorized to
2 enter into the attached Act of Donation with Mercy Partners, LLC, for the public purpose of
3 constructing water retention infrastructure at the site formerly known as Lindy Boggs Medical Center
4 for the benefit of the water, sewer, and drainage infrastructure for the City of New Orleans, and in turn
5 the health, welfare, and safety of the citizens in the City of New Orleans.

1 **SECTION 6.** That said Act of Donation is attached to this ordinance as Exhibit “C” and
2 incorporated herein and made a part hereof.

ADOPTED BY THE COUNCIL OF THE CITY OF NEW ORLEANS _____

PRESIDENT OF COUNCIL

DELIVERED TO THE MAYOR ON _____

APPROVED:

DISAPPROVED: _____

MAYOR

RETURNED BY THE MAYOR ON _____ **AT** _____

CLERK OF COUNCIL

ROLL CALL VOTE:

YEAS:

NAYS:

ABSENT:

RECUSED:

COOPERATIVE ENDEAVOR AGREEMENT

BY AND BETWEEN

THE CITY OF NEW ORLEANS

AND

MERCY PARTNERS, LLC

MERCY DRAINAGE AND STORMWATER RETENTION PROJECT

THIS COOPERATIVE ENDEAVOR AGREEMENT (the “**Agreement**”) is entered into by and between the City of New Orleans, represented by Helena Moreno, Mayor (the “**City**”) and Mercy Partners, LLC, represented by Paul Flower, Manager (“**Mercy**”). The City and Mercy may sometimes each be referred to as a “**Party**,” and collectively, as the “**Parties**.” The Agreement is effective as of the date of execution by the City (the “**Effective Date**”).

RECITALS

WHEREAS, the City is a political subdivision of the State of Louisiana;

WHEREAS, Mercy Partners, LLC is a Limited Liability Company of the State of Louisiana which principal address is located at 1000 S. Norman C. Francis Pkwy, New Orleans, LA 70125;

WHEREAS, pursuant to Article 7, Section 14(C) of the Louisiana Constitution of 1974, and related statutes, and Section 9-314 of the Home Rule Charter of the City of New Orleans, the City may enter into cooperative endeavors with the State of Louisiana, its political subdivisions and corporations, the United States and its agencies, and any public or private corporation, association, or individual with regard to cooperative financing and other economic development activities, the procurement and development of immovable property, joint planning and implementation of public works, the joint use of facilities, joint research and program implementation activities, joint funding initiatives, and other similar activities in support of public education, community development, housing rehabilitation, economic growth, and other public purposes;

WHEREAS, Mercy owns the land and the building located at 301 N. Norman C. Francis Pkwy., New Orleans, LA 70119, formerly known as the Lindy Boggs Medical Center (the “**Site**”);

WHEREAS, the City and Mercy desire to accomplish a valuable public purpose of establishing on the Site and for the benefit of the City a water retention control structure and system connected into the City’s existing storm drainage system (the “**Public Drainage System**”), which Public Drainage System is presently operated and maintained by the Sewerage and Water Board of New Orleans;

WHEREAS, as a prerequisite to constructing a water retention control structure on the Site, it is necessary to demolish the existing buildings on the Site;

WHEREAS, in furtherance of the foregoing, Mercy will demolish the existing buildings on the Site and design, engineer, and construct the water retention control structure and system conveyance, which design shall include capabilities of up to four million gallons of underground water retention (the “**Retention Area**”) and inflow and outflow structures (the “**Inflow and Outflow Structures**”) connected to the Public Drainage System (collectively, the “**Project**”);

WHEREAS, the Inflow and Outflow Structures will cross portions of the Site and the public right of way (collectively, the “**Inflow and Outflow Area**”);

WHEREAS, on November 15, 2025, pursuant to City Council Resolution No. R-25-427, a majority of the electors of the City authorized the issuance of up to \$415 million in general obligation bonds for the purpose of making capital improvements in the City (the “**Approved Bonds**”);

WHEREAS, the Approved Bonds will be used to fund the infrastructure projects described in City Council Resolution No. R-25-427, as amended by City Council Resolution No. R-25-524, which projects include redevelopment of the Site; and

WHEREAS, the City will use a portion of the proceeds of the Approved Bonds in the amounts described in Article II hereof and such other City funds as may be lawfully available (the “**Project Funds**”) to fund the Project and any additional costs related to the Project (the Project also referred to herein as the “**Mercy Drainage and Stormwater Retention Project**”).

NOW THEREFORE, the City and Mercy, each having the authority to do so, agree as follows:

ARTICLE I – OBLIGATIONS OF THE PARTIES

A. Obligations of Mercy. Mercy shall:

1. Design, engineer, and construct the Project at the Site owned by Mercy and the adjacent public right of way in accordance with the plans attached hereto as “**Exhibit A**” (the “**Plans**”). No changes may be made to the Plans without the prior written consent of the City;
2. Lease the Retention Area and the specified portion of the Inflow and Outflow Area owned by Mercy to the City pursuant to a lease in the form attached hereto as “**Exhibit B**” (the “**Lease**”);
3. Donate the Inflow and Outflow Structures located within the public right of way (the “**Public Inflow and Outflow Structures**”) to the City pursuant to an Act of Donation in the form attached hereto as “**Exhibit C**” (the “**Donation**”); and
4. Control, staff, operate, and maintain the Project (excluding the Public Inflow and Outflow Structures) on the terms and conditions described in the Lease and otherwise as required by applicable law.

B. Obligations of the City. The City shall:

1. Administer the Agreement through the Office of Community Development;

2. Fund the Project using the Project Funds, subject to the provisions of Article II, below;
3. Dedicate, appropriate, and release the Project Funds to Mercy pursuant to the Payment Schedule in Article II, below;
4. Intentionally Omitted.
5. To the fullest extent allowed by law, and in furtherance of the Project, work collaboratively with Mercy Partners to support the creation and establishment of an economic development district and Tax Increment Financing district (TIF) pursuant to Louisiana Revised Statute 33:9038.72. The use of any funds generated by such a district will be governed by a separate cooperative endeavor agreement (the “**EDD CEA**”) containing terms mutually acceptable to the parties thereto, but the City and Mercy Partners acknowledge their intent that these funds can be used for capital financing as well as ongoing operations and maintenance of the Project contemplated in this Agreement, subject to the terms and conditions described in the EDD CEA. Notwithstanding anything to the contrary contained herein, neither the City nor the City Council will be required to take any affirmative legislative action with respect to this provision;
6. Control, staff, operate, and maintain the Public Inflow and Outflow Structures on the terms and conditions described in the Lease.

ARTICLE II – FUNDING OR COMPENSATION

- A. **Maximum Amount.** The maximum amount funded by the City under this Agreement, is ELEVEN MILLION FIVE HUNDRED THOUSAND DOLLARS (\$11,500,000.00), comprised of the following:
 1. Maximum funding under the Drainage and Stormwater Bond proceeds is SIX MILLION DOLLARS (\$6,000,000.00).
 2. Maximum funding under the City Infrastructure Projects Bond proceeds is FIVE MILLION FIVE HUNDRED THOUSAND DOLLARS (\$5,500,000.00).
- B. There is no compensation to the City pursuant to this agreement; benefits accruing to the City include drainage improvements resulting from the Project .
- C. Annual expenses associated with the Lease are as detailed in the attached form of Lease.
- D. **Project Funding Schedule.** The City’s funding for the Project will be made according to the Project funding schedule attached hereto as “Exhibit D” (the “**Payment Schedule**”).
- E. The City’s funding obligations under this Agreement are subject to the successful issuance of 2026 Drainage and Stormwater and City Infrastructure Project Bonds. Any termination for non-appropriation is subject to the provisions under Article III of this Agreement.
- F. Mercy Partners will utilize the BRASS system for payments, or by any other means as may be lawfully available and agreed to by the Parties.

ARTICLE III - DURATION AND TERMINATION

A. **Term.** The term of this Agreement shall be for three (3) years from the Effective Date. The term of the Lease shall be for 99 years as described in the attached form of Lease.

B. **Termination for Cause.** The City or Mercy may terminate this Agreement for cause on written notice to the other Parties, if the other Party breaches any provision of this Agreement and either the breach cannot be cured or, if the breach can be cured, it is not cured within 30 days after the breaching Party's receipt of written notice of such breach.

C. **Termination for Non-Appropriation.** The City or Mercy shall have the right to terminate this Agreement immediately in the event of non-appropriation of funds sufficient to maintain the Project and/or the purpose of this Agreement without the requirement of notice, and no Party shall be liable for any amounts, funds or liabilities accrued to it for the Project beyond the City funds appropriated, encumbered and paid to Mercy.

ARTICLE IV – INTENTIONALLY OMITTED

ARTICLE V – INSURANCE

A. Except as otherwise noted, at all times during this Agreement or the performance of work required by this Agreement, Mercy will maintain or cause to be maintained, the following insurance, as specified in items B through I below, in full force and effect for the duration of the work under this Agreement. Evidence of coverage shall be provided prior to the start of any activities/work, in conjunction with Mercy's obligations and/or scope of work under the Agreement.

If Mercy maintains broader coverage and/or higher limits than the minimums shown below, the City requires and shall be entitled to the broader coverage and/or the higher limits maintained by Mercy. Any available insurance proceeds in excess of the specified minimum limits of insurance and coverage shall be available to the City, with the following minimum requirements (“**Minimum Requirements**”):

B. Workers' Compensation & Employers Liability

1. Insurance in compliance with the Louisiana Workers' Compensation Act(s). Statutory and Employers Liability Insurance with limits of not less than \$1,000,000. All employers must provide this insurance or be registered as a “Self-Insured” entity within the State of Louisiana.

C. Commercial General Liability

1. Insurance including contractual liability insurance, products and completed operations, personal & advertising injury, bodily injury, property damage, products/completed operations, and any other type of liability for which this Agreement applies with limits of liability of not less than \$2,000,000 each occurrence / \$4,000,000 policy aggregate.

D. Automobile Liability

1. Insurance with a combined single limit of liability of not less than \$1,000,000 per accident for bodily injury and property damage. Insurance shall include all owned, non-owned and hired vehicles. If transporting any pollutants, as defined by the policy, the policy is to include applicable Pollution coverage.

E. Umbrella Liability (where applicable)

1. Umbrella/Excess policies must “Follow form” of the underlying policies and scheduling.

F. Builders Risk (coverage should not be bound until a Notice to Proceed (NTP) is issued for a project)

1. Builder’s Risk (Course of Construction) Insurance utilizing an “All Risk” (Special Perils) coverage form, on a replacement cost basis, including coverage on the entire Project, to include but not limited to coverage for Flood and Named Storm, Fire, Theft, Mysterious Disappearance (if available), Damages due to Changes or Extremes of Temperature, Property of others in the care, custody or control, Debris Removal, Vandalism and Soft Cost (i.e. professional services, permits, etc.), with limits equal to the completed value of the project and no coinsurance penalty provisions.
2. Policy shall include coverage during transit, installation and while materials are being stored off site. Such coverage shall name the City of New Orleans as a Loss Payee as their interest may appear.
3. If not covered under the “all-risk” insurance or otherwise provided in the Agreement, Mercy shall effect and maintain similar insurance on portions of the work stored off the site when such portions of the work are to be included in any applications for payment and such procedures have been approved by the City.
4. Builders’ Risk Insurance shall be written and provide such that any portions of a building or site vacated by the City to accommodate the work are protected and covered by the terms of the policy. The insurance shall not be cancelled or permitted to lapse due to such vacancy.
5. Mercy shall obtain consent of the insurance carrier that no action will be taken with respect to partial occupancy or use that would cause cancellation, lapse or reduction of insurance.

G. Contractors Pollution Liability (where applicable) – Mercy shall maintain Contractors’ Pollution Liability Insurance (or equivalent coverage) applicable to the work being performed with limits of not less than \$2,000,000 per occurrence or claim / \$2,000,000 policy aggregate, covering losses caused by pollution conditions that arise from the handling, transporting, disposal and related contractor activities/operations. Insurance shall apply to bodily injury, property damage, including loss of use of damaged property that has not been physically impacted and defense, including cost and expenses incurred in

the investigation, defense, or settlement of claims. Coverage shall include but not be limited to Fines, Penalties, Punitive Damages and Clean-up cost.

H. Professional Liability Insurance - As professional services are required under the Agreement, insurance is appropriate to the contractor's profession, with limits of liability of not less than \$2,000,000 per occurrence or claim / \$2,000,000 policy aggregate. Coverage shall be sufficiently broad to respond to the duties and obligations as is undertaken by Mercy in this agreement. Policy shall be kept in force and uninterrupted for a period of three (3) years beyond policy expiration. If coverage is discontinued for any reason during this three (3) year term, Mercy must procure and evidence full extended reporting period (ERP) coverage.

I. General Provision and Requirements

1. Mercy shall be able to meet the above referenced specific policy limits of liability through a combination of primary and umbrella/excess coverage
2. The obligations for Mercy to procure and maintain insurance shall not be constructed to waive or restrict other obligations. It is understood that neither failure to comply nor full compliance with the foregoing insurance requirements shall limit or relieve Mercy from any liability incurred as a result of its activities/operations in conjunction with Mercy's obligations and/or scope of work under the Agreement. Mercy shall be responsible for any losses, expenses, damages, claims and/or suits and cost of any kind which exceed Mercy's limits of liability that arise from the performance of work under the Agreement.
3. Certificates of Insurance Additional Insured Status:
 - i. Mercy and all contractors and subcontractors (where applicable) will provide, and maintain current, a Certificate of Insurance naming the City of New Orleans, its departments, political subdivisions, officers, officials, employees, and volunteers as "Additional Insureds" on the CGL and AL policies with respect to liability arising out of the performance of this Agreement.
 - ii. Additional Insured coverage should be provided in the form of an endorsement to the Mercy/contractor's/subcontractor's insurance, at least as broad as ISO Form CG 20 10 11 85 or both CG 20 10 and CG 20 37 forms (if later revisions are used). The Certificate of Insurance, as evidence of all required coverage, shall name the City of New Orleans - Risk Manager as Certificate Holder and be delivered via U.S. Mail to Eldridge A. Morris, Risk Manager, City of New Orleans, 1300 Perdido Street, Suite 9E06, New Orleans, LA 70112.
 - iii. Mercy shall require and verify that all contractors and subcontractors maintain insurance and coverage limits meeting all the requirements stated herein or the contractor's or subcontractor's liability shall be covered by Mercy.

- iv. The Additional Insured box shall be marked “Y” for Commercial General Liability coverage. The Subrogation Waiver Box must be marked “Y” for Workers Compensation/Employers Liability.

4. General Requirements:

- i. Primary Coverage: For any claims, liability, demands and/or suits related to this Agreement or Mercy’s performance and furnishing of the work, whether it is performed by a contractor, subcontractor, partner, supplier or by anyone directly or indirectly employed by any of them to perform or furnish any of the work. Mercy’s insurance coverage shall be primary insurance in respect of the City, its departments, political subdivisions, officers, officials, employees, and volunteers. Any insurance or self-insurance maintained by the City shall be non-contributing to Mercy’s coverage. At no time shall Mercy allow any contractor or subcontractor to perform work without the required types and limits of required insurance coverage.
- ii. The carriers/companies issuing the policies of insurance shall not have any recourse against the City for payment of any premiums, deductibles, and retentions or for assessments under any form of policy. These shall be borne by and be the sole responsibility of Mercy.
- iii. Claims Made Policies: If applicable, the retroactive date must be shown and must be before the date of the Agreement or the beginning of work. If the coverage is canceled or non-renewed, and not replaced with another claims-made policy, Mercy must purchase “extended reporting” coverage for minimum of 3 years after the termination of this Agreement.
- iv. Waiver of Subrogation: Mercy and its insurers agree to waive any right of subrogation which any insurer may acquire against the City by virtue of the payment of any loss under insurance required by this Agreement.
- v. Notice of Cancellation: Each insurance policy shall not be canceled, allowed to expire or altered except with prior notice to the City of no less than 30 days.
- vi. Acceptability of Insurers: Insurance is to be placed with insurers licensed and authorized to do business in the State of Louisiana with a current A.M. Best’s rating of no less than A: VII, unless otherwise acceptable to the City.
- vii. If the City has any objection to the coverage afforded by or any other provisions of the insurance required to be purchased and maintained by Mercy in accordance with the insurance requirements, the City shall notify the Mercy in writing within thirty (30) days after receipt of the Certificates. Mercy shall provide a written response to the objection within ten (10) days from the date of the notice.

- viii. Upon failure of Mercy or its contractors or subcontractors to purchase, furnish, deliver or maintain such insurance as provided herein, the Agreement, at the discretion of the City may be forthwith declared suspended, discontinued, or terminated. Failure of Mercy or its contractors or subcontractors to purchase and maintain insurance shall not relieve Mercy from any liability under the Agreement, nor shall the insurance requirements be constructed to conflict with the obligations of Mercy concerning indemnification.
 - ix. Notice: Mercy Partners will provide the City's Risk Manager, at City of New Orleans Attn: Risk Manager, 1300 Perdido Street, Suite 9E06, New Orleans, LA 70112- Ref.: CEA) the following documents, within 10 calendar days of the City's request - Copies of all policies of insurance, including all policies, forms, and endorsements.
5. Miscellaneous: Without notice from the City, Mercy will:
- i. Replenish any policy aggregate limit that is impaired before commencement of any work or continuation of any work under this Agreement.
 - ii. Substitute insurance coverage acceptable to the City within 30 calendar days if any insurance company providing any insurance with respect to this Agreement is declared bankrupt, becomes insolvent, loses the right to do business in Louisiana, or ceases to meet the requirements of this Agreement.
6. Special Risks or Circumstances:

Special Risks or Circumstances: The City shall reserve the right to modify these requirements, including limits, based on the nature of the risk, prior experience, insurance coverage, or other circumstances, based on any change in the scope of work and/or Mercy's obligations.

ARTICLE VI - NON-DISCRIMINATION

A. Equal Employment Opportunity. In all hiring or employment made possible by, or resulting from this Agreement, Mercy (1) will not discriminate against any employee or applicant for employment because of race, color, religion, sex, gender, age, physical or mental disability, national origin, sexual orientation, creed, culture, or ancestry, and (2) where applicable, will take affirmative action to ensure that its employees are treated during employment without regard to their race, color, religion, sex, gender, age, physical or mental disability, national origin, sexual orientation, creed, culture, or ancestry. This requirement shall apply to, but not be limited to the following: employment, upgrading, demotion or transfer, recruitment or recruitment advertising, layoff or termination, rates of pay or other forms of compensation, and selection for training, including apprenticeship. All solicitations or advertisements for employees shall state that all qualified applicants will receive consideration for employment without regard to race, color, religion, sex, gender, age, physical or mental disability, national origin, sexual orientation, creed, culture, or ancestry.

B. Non-Discrimination. In the performance of this Agreement, Mercy will not discriminate on the basis, whether in fact or perception, of a person's race, color, creed, religion, national origin, ancestry, age, sex, gender, sexual orientation, gender identity, domestic partner status, marital status, physical or mental disability, or AIDS- or HIV-status against (1) any employee of the City working with the Parties in any of Parties operations within Orleans Parish or (2) any person seeking accommodations, advantages, facilities, privileges, services, or membership in all business, social, or other establishments or organizations operated by Mercy. Mercy agrees to comply with and abide by all applicable federal, state and local laws relating to non-discrimination, including, without limitation, Title VI of the Civil Rights Act of 1964, Section V of the Rehabilitation Act of 1973, and the Americans with Disabilities Act of 1990.

ARTICLE VII - INDEPENDENT CONTRACTOR

A. Independent Contractor Status. For the limited purpose of the scope and delivery of the Project, Mercy shall be considered an independent contractor and shall not be deemed an employee, servant, agent, partner, or joint venture of the City, and will not hold itself or any of its employees, subcontractors or agents to be an employee, partner, or agent of the City.

B. Exclusion of Worker's Compensation Coverage. The City will not be liable to Mercy as an independent contractor as defined in La. R.S. 23:1021(6), for any benefits or coverage as provided by the Workmen's Compensation Law of the State of Louisiana. Under the provisions of La. R.S. 23:1034, any person employed by Mercy will not be considered an employee of the City for the purpose of Worker's Compensation coverage.

C. Waiver of Benefits. Mercy as an independent contractor, will not receive from the City any sick and annual leave benefits, medical insurance, life insurance, paid vacations, paid holidays, sick leave, pension, or Social Security for any services rendered to the City under this Agreement.

ARTICLE VIII - NOTICE

A. In General. Except for any routine communication, any notice, demand, communication, or request required or permitted under this Agreement will be given in writing and delivered in person or by certified mail, return receipt requested as follows:

1. To the City:

Jeffrey Schwartz
Director of Housing, Community Development, and Special Projects
City of New Orleans
1340 Poydras Street, Suite 1000
New Orleans, LA 70112

&

City Attorney
City of New Orleans
1300 Perdido Street, Suite 5E03
New Orleans, LA 70112

2. To Mercy Partners, LLC:

Mercy Partners, LLC
Attention: Paul Flower
1000 S. Norman C. Francis Pkwy
New Orleans, LA 70125

B. Effectiveness. Notices are effective when received, except any notice that is not received due to the intended recipient's refusal or avoidance of delivery is deemed received as of the date of the first attempted delivery.

C. Notification of Change. Each party is responsible for notifying the other in writing that references this Agreement of any changes in its address(es) set forth above.

ARTICLE IX - ADDITIONAL PROVISIONS

A. Amendment. No amendment of or modification to this Agreement shall be valid unless and until executed in writing by the duly authorized representatives of the Parties to this Agreement.

B. Assignment. This Agreement and any part of the interest in it are not assignable or transferable without the other Parties' prior written consent.

C. Audit and Other Oversight. Mercy will abide by all provisions of City Code § 2-1120, including without limitation City Code § 2-1120(12), which requires Mercy to provide the Office of Inspector General with documents and information as requested and limited to the Project. Failure to comply with such requests is a material breach of the Agreement. In signing this Agreement, Mercy agrees that it is subject to the jurisdiction of the Orleans Parish Civil District Court for purposes of challenging a subpoena.

D. Choice of Law. This Agreement will be construed and enforced in accordance with the laws of the State of Louisiana without regard to its conflict of laws provisions.

E. Construction of Agreement. No Party will be deemed to have drafted this Agreement. This Agreement has been reviewed by the Parties and shall be construed and interpreted according to the ordinary meaning of the words used so as to fairly accomplish the purposes and intentions of the Parties. No term of this Agreement shall be construed or resolved in favor of or against any Party on the basis of which party drafted the uncertain or ambiguous language. The headings and captions of this Agreement are provided for convenience only and are not intended to have effect in the construction or interpretation of this Agreement. Where appropriate, the singular includes the plural and neutral words and words of any gender shall include the neutral and other gender.

F. Entire Agreement. This Agreement, including all incorporated documents, constitutes the final and complete agreement and understanding between the Parties. All prior and contemporaneous agreements and understandings, whether oral or written, are superseded by this Agreement and are without effect to vary or alter any terms or conditions of this Agreement.

G. Exhibits. The following exhibits will be and are incorporated into this Agreement:

1. Exhibit A – Plans

2. Exhibit B – Lease
3. Exhibit C – Donation
4. Exhibit D – Payment Schedule

H. Jurisdiction. Because of the nature and complexity of the obligations to be undertaken under this Agreement, the Parties agree that nonbinding mediation shall serve as the initial method for resolving any disputes related to or arising out of the obligations contemplated under this Agreement (each, a “**Dispute**”). Either Party may initiate mediation by written notice to the other Party or Parties, as applicable, identifying the Dispute and proposing at least three qualified, neutral mediators. The Parties shall jointly select a mediator within 15 days of the notice, and the mediation shall be held within 45 days thereafter, unless the Parties agree in writing to extend these periods. The mediation shall take place in New Orleans, Louisiana, and the Parties shall share the mediator's fees and expenses equally, provided that each Party shall bear its own attorneys' fees and costs. Completion of one mediation session (lasting at least one full day, unless earlier terminated by the mediator) or 60 days having passed after the mediator's appointment, whichever occurs first, shall satisfy this requirement and shall be a condition precedent to the initiation of any lawsuit arising out of the same Dispute. In the event any dispute may not be reasonably resolved through mediation, the Parties will consent to the jurisdiction of the State Civil Courts of the Parish of Orleans and will formally waive any pleas of jurisdiction on account of residence elsewhere.

I. Limitations of the City's Obligations. The City has no obligations not explicitly set forth in this Agreement or any incorporated documents or expressly imposed by law.

J. No Expectation of Benefit or Special Treatment. Mercy swears that, as a result of the donation of the services that are the subject of this Agreement or otherwise, it has no expectation of benefit or special treatment with regard to other contracts or potential contracts with the City.

K. No Third-Party Beneficiaries. This Agreement is entered into for the exclusive benefit of the Parties and the Parties expressly disclaim any intent to benefit anyone not a party to this Agreement.

L. Non-Waiver. The failure of any Party to insist upon strict compliance with any provision of this Agreement, to enforce any right or to seek any remedy upon discovery of any default or breach of another Party at such time as the initial discovery of the existence of such noncompliance, right, default or breach shall not affect or constitute a waiver of such Party's right to insist upon such compliance, exercise such right or seek such remedy with respect to that default or breach or any prior contemporaneous or subsequent default or breach.

M. Prohibition of Financial Interest in Agreement. No elected official or employee of the City shall have a financial interest, direct or indirect, in this Agreement. For purposes of this provision, a financial interest held by the spouse, child, or parent of any elected official or employee of the City shall be deemed to be a financial interest of such elected official or employee of the City. Any willful violation of this provision, with the expressed or implied knowledge of Mercy, shall render this Agreement voidable by the City and shall entitle the City to recover, in addition to any other rights and remedies available to the City, all monies paid by the City to the Project pursuant to this Agreement.

N. Prohibition on Political Activity. None of the funds, materials, property, or services provided directly or indirectly under the terms of this Agreement shall be used in the performance of this Agreement for any partisan political activity, or to further the election or defeat of any candidate for public office.

O. Remedies Cumulative. No remedy set forth in the Agreement or otherwise conferred upon or reserved to any Party shall be considered exclusive of any other remedy available to a party. Rather, each remedy shall be deemed distinct, separate and cumulative and each may be exercised from time to time as often as the occasion may arise or as may be deemed expedient.

P. Severability. Should a court of competent jurisdiction find any provision of this Agreement to be unenforceable as written, the unenforceable provision should be reformed, if possible, so that it is enforceable to the maximum extent permitted by law or, if reformation is not possible, the unenforceable provision shall be fully severable and the remaining provisions of the Agreement shall remain in full force and effect and shall be construed and enforced as if the unenforceable provision was never a part the Agreement.

Q. Survival of Certain Provisions. All representations and warranties and all obligations concerning record retention, inspections, audits, ownership, payment, remedies, jurisdiction, and choice of law shall survive the expiration, suspension, or termination of this Agreement and continue in full force and effect.

R. Terms Binding. The terms and conditions of this Agreement are binding on any heirs, successors, transferees, and assigns.

ARTICLE X – COUNTERPARTS

This Agreement may be executed in one or more counterparts, each of which shall be deemed to be an original copy of this Agreement, but all of which, when taken together, shall constitute one and the same agreement.

ARTICLE XI - ELECTRONIC SIGNATURE AND DELIVERY

The Parties agree that a manually signed copy of this Agreement and any other document(s) attached to this Agreement delivered by email shall be deemed to have the same legal effect as delivery of an original signed copy of this Agreement. No legally binding obligation shall be created with respect to a Party until such Party has delivered or caused to be delivered a manually signed copy of this Agreement.

[SIGNATURES CONTAINED ON NEXT PAGE]

[The remainder of this page is intentionally left blank.]

IN WITNESS WHEREOF, the City and Mercy, through their duly authorized representatives, execute this Agreement.

CITY OF NEW ORLEANS

BY: _____
HELENA MORENO, MAYOR

Executed on this _____ of _____, 2026.

**FORM AND LEGALITY APPROVED BY:
THE LAW DEPARTMENT**

By: _____

Printed Name: _____

MERCY PARTNERS, LLC

BY: _____
PAUL FLOWER, MANAGER

FEDERAL TAX I.D. NO.

(EXHIBITS A-D ATTACHED ON THE FOLLOWING PAGES)

GENERAL NOTES

1. CONTRACTOR SHALL FIELD VERIFY ALL DIMENSIONS, LOCATIONS AND ELEVATIONS SHOWN ON DRAWINGS. ALL DISCREPANCIES SHALL BE BROUGHT TO THE ATTENTION OF THE ENGINEER BEFORE PROCEEDING WITH THE WORK.
2. FOR NOTES PERTAINING TO INDIVIDUAL STRUCTURES, SEE DRAWINGS FOR THOSE STRUCTURES.
3. CONSTRUCTION LOADS FOR ANY NEW PORTION OF THE STRUCTURE SHALL NOT BE IMPOSED UNTIL THE CONCRETE CYLINDER STRENGTH FOR THOSE MEMBERS AND CONNECTING POURS HAS REACHED 80% OF THE 28 DAY CONCRETE COMPRESSIVE STRENGTH.

CODES AND STANDARDS

1. AASHTO, AMERICAN ASSOCIATION OF STATE HIGHWAY AND TRANSPORTATION OFFICIALS, STANDARD SPECIFICATIONS FOR HIGHWAY BRIDGES, 2002
2. ACI 318, AMERICAN CONCRETE INSTITUTE, BUILDING CODE REQUIREMENTS FOR STRUCTURAL CONCRETE AND COMMENTARY, 2014 EDITION
3. ACI 301, AMERICAN CONCRETE INSTITUTE, SPECIFICATIONS FOR STRUCTURAL CONCRETE, 2016 EDITION
4. ANS/AISC 360, AMERICAN INSTITUTE OF STEEL CONSTRUCTION SPECIFICATIONS FOR STRUCTURAL STEEL BUILDINGS, 2016 EDITION
5. AISC, AMERICAN INSTITUTE OF STEEL CONSTRUCTION, STEEL CONSTRUCTION MANUAL, 14TH EDITION, 2010
6. ASCE 7, AMERICAN SOCIETY OF CIVIL ENGINEERS, MINIMUM DESIGN LOADS FOR BUILDINGS AND OTHER STRUCTURES, 2016 EDITION (ASCE 7-05 USED FOR PIER STRUCTURES ONLY)
7. ASCE 24, AMERICAN SOCIETY OF CIVIL ENGINEERS, FLOOD RESISTANT DESIGN AND CONSTRUCTION, 2014 EDITION

CONCRETE NOTES

1. CONCRETE NOTES BELOW ARE APPLICABLE TO CONCRETE INLET AND OUTLET CONTROL DRAINAGE STRUCTURES.
2. PROVIDE STRUCTURAL CONCRETE AS FOLLOWS:
MINIMUM CONCRETE COMPRESSIVE STRENGTH (fc) AT 28 DAYS SHALL BE AS FOLLOWS:
 - a. CAST-IN-PLACE CONCRETE 5,000 PSI
 - b. PRECAST CONCRETE (UTILITY VAULTS) 5,000 PSI
 - c. ALL CONCRETE FOR DRAINAGE STRUCTURES OR WALL PATCHES SHALL UTILIZE XYPEX C-500 OR C-500 NF WATERPROOFING ADMIXTURE AT THE FOLLOWING RATES:
 C-500 - 15 POUNDS / CY OF CONCRETE
 C-500 NF - 7.5 POUNDS / CY OF CONCRETE
3. ALL GROUT SHALL BE NON-SHRINK, NON-CORROSIVE, NON-METALLIC HAVING A MINIMUM COMPRESSIVE STRENGTH OF 8,000 PSI, UON.
4. DETAIL AND CONSTRUCT REINFORCED CONCRETE IN ACCORDANCE WITH AMERICAN CONCRETE INSTITUTE ACI 301, "SPECIFICATION FOR STRUCTURAL CONCRETE."
5. DETAIL REINFORCING STEEL IN ACCORDANCE WITH AMERICAN CONCRETE INSTITUTE ACI 315, "MANUAL OF STANDARD PRACTICE FOR DETAILING REINFORCED CONCRETE STRUCTURES," AND ACI SP-66, "ACI DETAILING MANUAL."
6. MINIMUM COVER FOR REINFORCING STEEL: 3" FOR CIP, AND 2" FOR CONCRETE PRECAST UNDER PLANT CONDITIONS.
7. STRUCTURAL CONCRETE REINFORCEMENT MATERIALS:
 - A. ALL SPLICES WILL BE CLASS "B" TENSION LAP SPLICES.
 - B. REINFORCING STEEL AND DOWEL BARS:ASTM A955, GRADE 60 UON
 - C. HEADED REINFORCEMENT:ASTM A970, GRADE 60
8. SUBMIT REINFORCING STEEL DETAILS (SHOP DRAWINGS) AND RECEIVE APPROVAL BEFORE PROCEEDING WITH FABRICATION.
9. ALL EXPOSED EXTERNAL CORNERS OF CONCRETE SHALL BE CHAMFERED WITH 3/4-INCH, 45-DEGREE CHAMFERS, UNLESS OTHERWISE NOTED.
10. PROVIDE JOINTS AS DETAILED AND SPECIFIED. NO ADDITIONAL JOINTS SHALL BE USED NOR ANY OMITTED EXCEPT BY WRITTEN AUTHORIZATION FROM THE ENGINEER.
11. ROUGHEN SURFACE OF ALL HORIZONTAL CONSTRUCTION JOINTS TO 1/4" FULL AMPLITUDE.

POST-INSTALLED ANCHOR NOTES

1. ALL POST-INSTALLED ANCHORS SHALL BE SECURED USING EPOXY GROUT, EPOXY ADHESIVE, OR ACRYLIC ADHESIVE, UNLESS OTHERWISE NOTED.
2. ANCHORS SHALL BE INSTALLED IN CONFORMANCE WITH THE MANUFACTURER'S RECOMMENDATIONS.
3. UNLESS OTHERWISE APPROVED, HOLES TO RECEIVE ANCHORS OR DOWELS SHALL BE DRILLED WITH A ROTARY IMPULSE TYPE DRILL.
4. PRIOR TO DRILLING, LOCATE EXISTING REINFORCEMENT. SHIFT DOWEL LOCATIONS TO PREVENT DAMAGING THE EXISTING REINFORCEMENT.
5. ANCHORS SHALL NOT BE DISTURBED DURING THE SET TIME OF THE GROUT/ADHESIVE.
6. ANCHOR SHALL NOT BE EPOXY COATED AND SHALL BE FREE OF OIL, SCALE AND RUST.
7. STAINLESS STEEL ANCHORS SHALL BE ISOLATED FROM GALVANIZED STEEL.
8. PROOF TEST ANCHORS IN ACCORDANCE WITH SPECIFICATIONS, UNLESS OTHERWISE NOTED.

DRAWING SCALES SHOWN BASED ON 30"x42" DRAWING

301 MAIN ST., SUITE 800
 BATON ROUGE, LA 70801
 225-336-2075
 WWW.MOFFATTNICHOL.COM

MERCY PARTNERS, LLC
 1000 S NORMAN C, FRANCIS PARKWAY
 NEW ORLEANS, LA 70125

Mark	Description	Date	Appr.

Designed by: TRR
 Date: 26-04-01
 Rev: 0

Drawn by: BDF
 Check by: TRR
 M&N Project No: 243137

Reviewed by: TRR
 Drawing code:

Submitted by: MOFFATT & NICHOL
 Dwg Scale: AS NOTED
 Plot scale: 1:1 (ARCH E1)

**MERCY HOSPITAL
 STORM DRAIN SYSTEM**

**INLET AND OUTLET
 CONTROL STRUCTURE
 GENERAL NOTES**

Sheet Reference Number:
C-001
 Sheet 1 of 8

**100% FOR REVIEW
 ISSUED: 2026-04-01
 NOT TO BE USED FOR CONSTRUCTION**

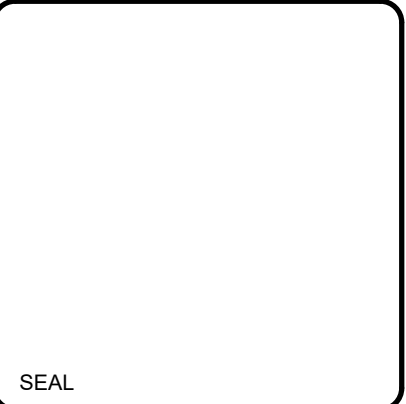

File: P:\BR24\13720\CADD_Archive_Sheets\0424137C-001.dwg, Printed: 4/1/2026 3:43 PM, by: FORD, BRANN, Shiver, 4/1/2026 3:42 PM, by: BCFORD

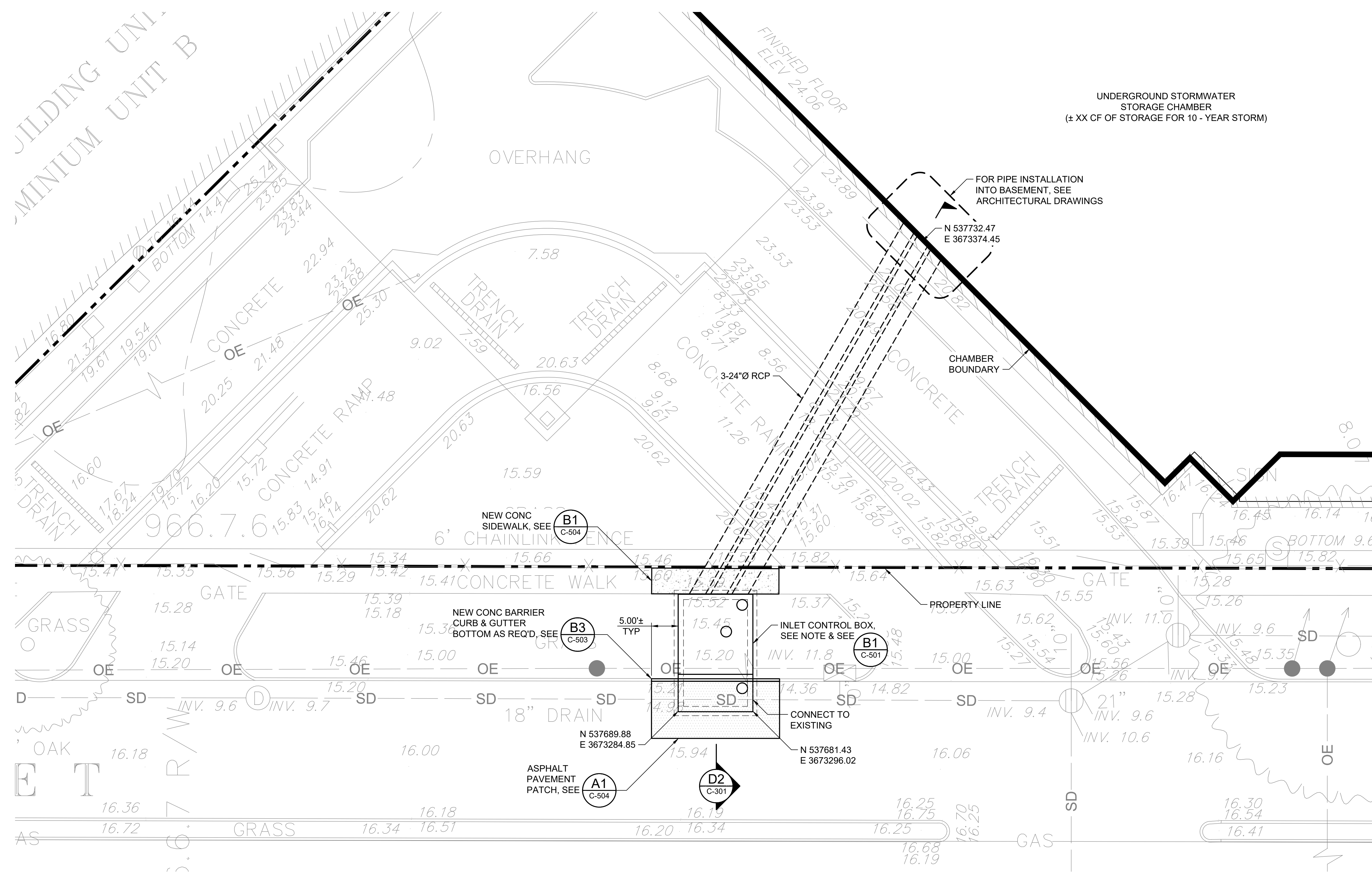
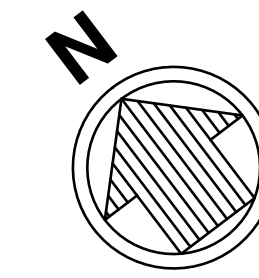

NOTE:

CONTRACTOR MAY ADJUST FINAL POSITION OF CONTROL BOX TO ADJUST FOR ACTUAL LOCATION AND CONNECTION OF EXISTING 18" STORM DRAIN.

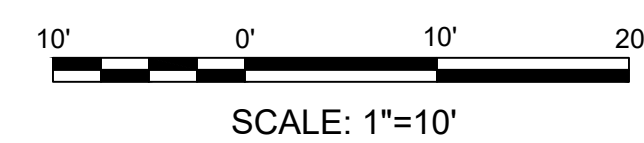

DRAWING SCALES SHOWN BASED ON 30"x42" DRAWING

		301 MAIN ST., SUITE 800 BATON ROUGE, LA 70801 225-336-2075 WWW.MOFFATTNICHOL.COM	
DESIGNED BY: TRR DATE: 26-04-01 REV: 0		CHECKED BY: TRR M&N PROJECT NO: 243137	
DRAWN BY: BDF REVIEWED BY: TRR		DRAWING CODE:	
SUBMITTED BY: MOFFATT & NICHOL		DWG SCALE: AS NOTED PLOT SCALE: 1:1 (ARCH E1)	
MERCY HOSPITAL STORM DRAIN SYSTEM			SHEET Reference Number: C-101 Sheet 2 of 8
SOUTH ENLARGED PLAN			

**100% FOR REVIEW
ISSUED: 2026-04-01
NOT TO BE USED FOR CONSTRUCTION**

SEAL

File: P:\BR\24113720\CADD_Aerial_Sheets\241137C-101_Plot.dwg, 4/1/2026 3:43 PM, by: FORD, BRAMAN, Saved: 2/26/2026 1:18 PM, by: BCFORD

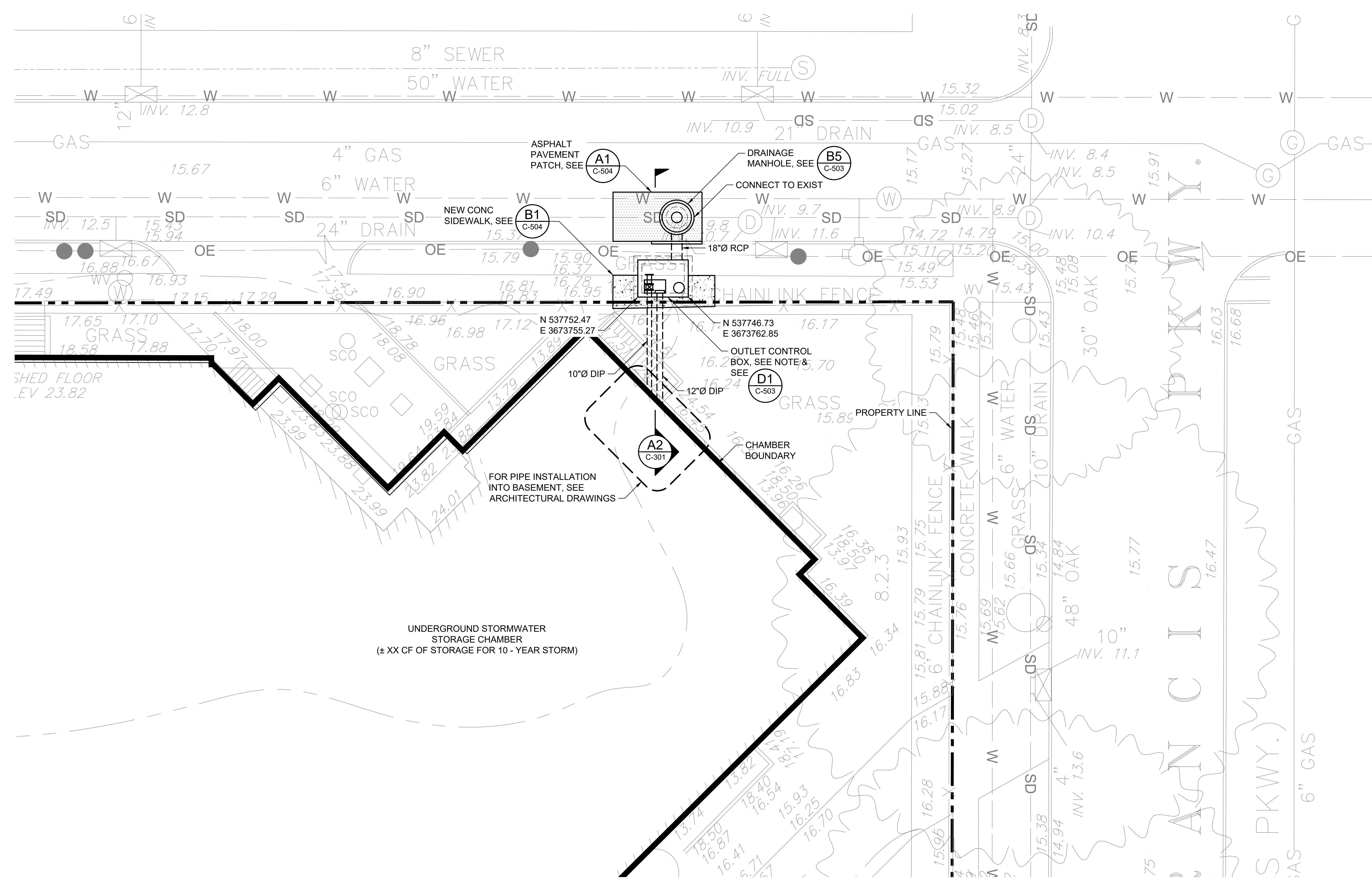
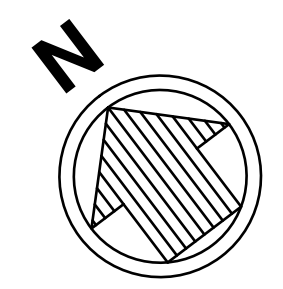

NOTE:
 CONTRACTOR MAY SLIGHTLY ADJUST FINAL POSITION OF OUTLET CONTROL BOX.

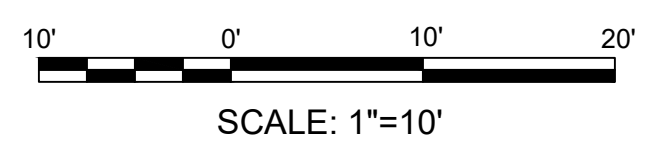

DRAWING SCALES SHOWN BASED ON 30"x42" DRAWING

		301 MAIN ST., SUITE 800 BATON ROUGE, LA 70801 225-336-2075 WWW.MOFFATTNICHOL.COM	
MERCY PARTNERS, LLC 1000 S NORMAN C. FRANCIS PARKWAY NEW ORLEANS, LA 70125		Mark	Description
Date: 26-04-01 Rev: 0	Designed by: TRR Drawn by: BDF Reviewed by: TRR Submitted by: MOFFATT & NICHOL	M&N Project No: 243137 Drawing code:	Date:

**MERCY HOSPITAL
 STORM DRAIN SYSTEM**
 NORTH ENLARGED PLAN

Sheet Reference Number:
C-102
 Sheet 3 of 8

**100% FOR REVIEW
 ISSUED: 2026-04-01
 NOT TO BE USED FOR CONSTRUCTION**



File: P:\BR\24113720\CADD_Aerial_Sheets\241137C-102.dwg, Printed: 4/1/2026 3:43 PM by FORD, BRAMAN, Saved: 2/26/2026 1:19 PM by BCFORD

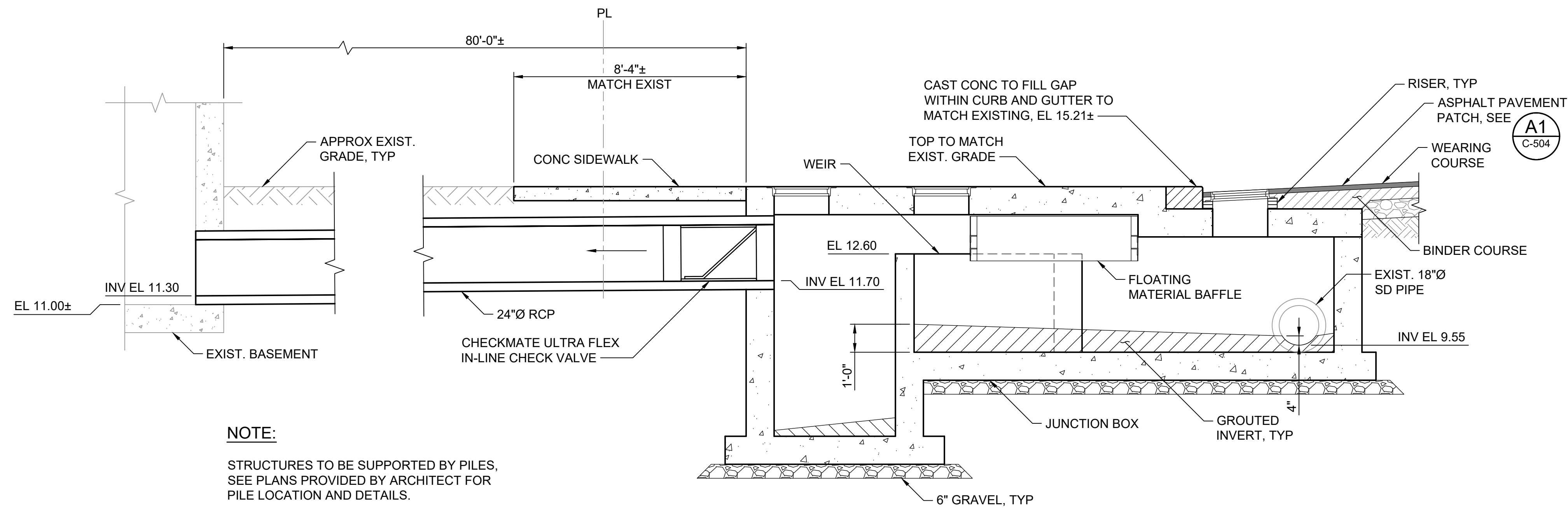

NOTE:
STRUCTURES TO BE SUPPORTED BY PILES.
SEE PLANS PROVIDED BY ARCHITECT FOR
PILE LOCATION AND DETAILS.

D2 SECTION
SCALE: 3/8"=1'-0"

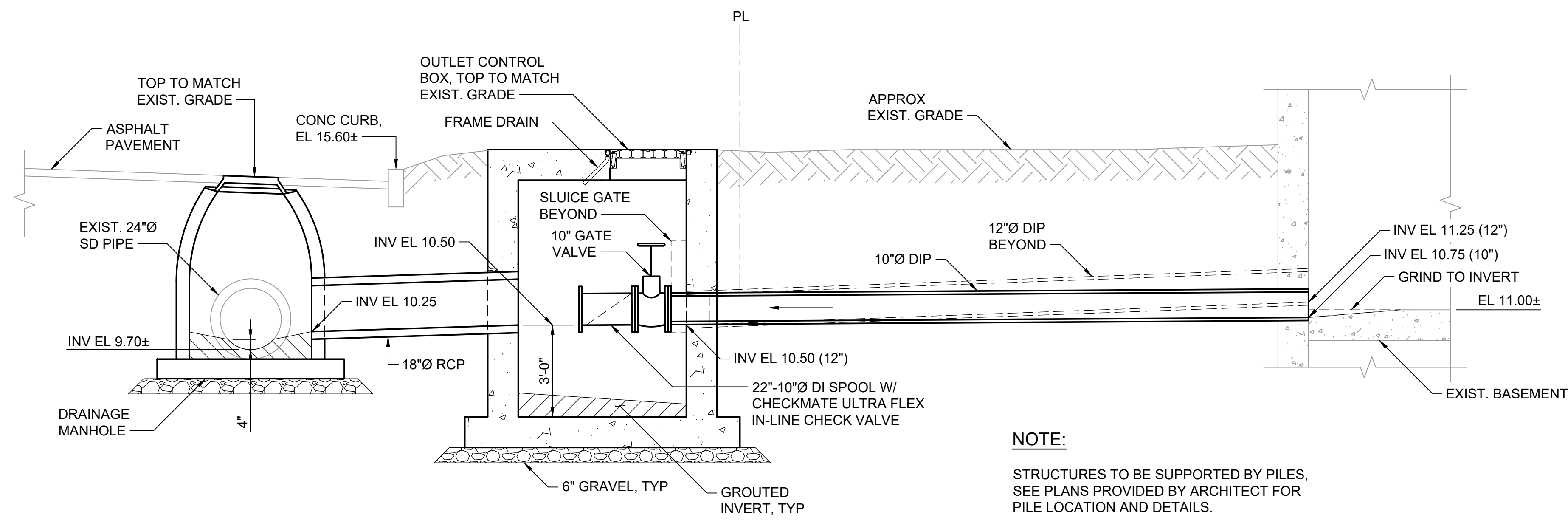

NOTE:
STRUCTURES TO BE SUPPORTED BY PILES.
SEE PLANS PROVIDED BY ARCHITECT FOR
PILE LOCATION AND DETAILS.

A2 SECTION
SCALE: 3/8"=1'-0"

File: P:\BR\24113720\CADD_Active_Sheets\241137C-301_Plot.dwg, 4/1/2026 3:43 PM by FORD, BRANN, Sheet: 2/8/2026 1:20 PM by FORD

4'-0" 0'-0" 2'-0" 4'-0"
SCALE: 3/8"=1'-0"

DRAWING SCALES SHOWN BASED ON 30"x42" DRAWING

		301 MAIN ST., SUITE 800 BATON ROUGE, LA 70801 225-336-2075 WWW.MOFFATTNICHOL.COM	
DESIGNED BY: TRR DATE: 26-04-01 DRAWN BY: BDF CHECKED BY: TRR REVIEWED BY: TRR SUBMITTED BY: MOFFATT & NICHOL		MERCY PARTNERS, LLC 1000 S NORMAN C, FRANCIS PARKWAY NEW ORLEANS, LA 70125	
SHEET REFERENCE NUMBER: C-301		SHEET 4 OF 8	

100% FOR REVIEW
ISSUED: 2026-04-01
NOT TO BE USED FOR CONSTRUCTION

SEAL

MERCY HOSPITAL
STORM DRAIN SYSTEM
TYPICAL SECTIONS

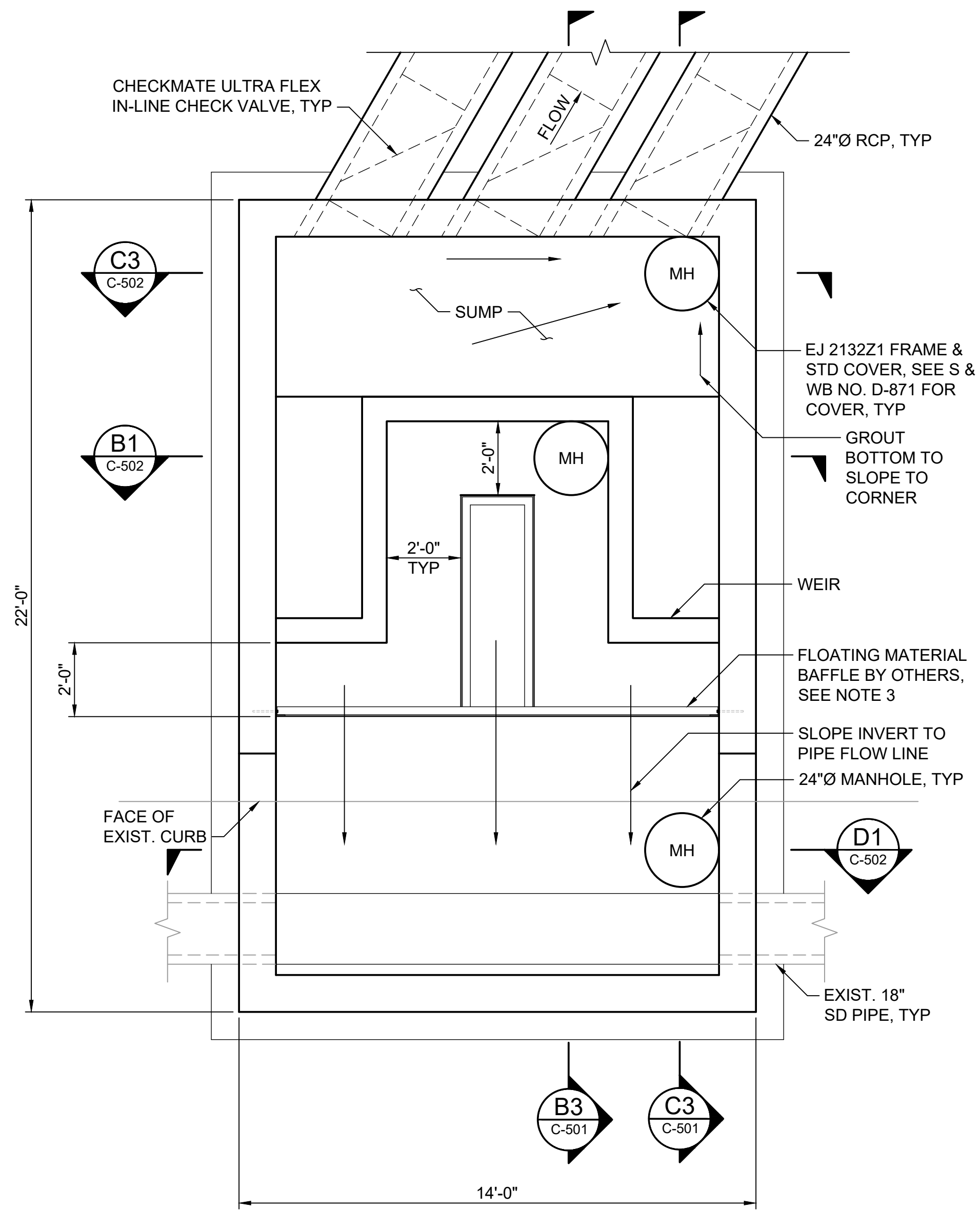

B1
C-501
INLET CONTROL BOX
SCALE: 3/8"=1'-0"

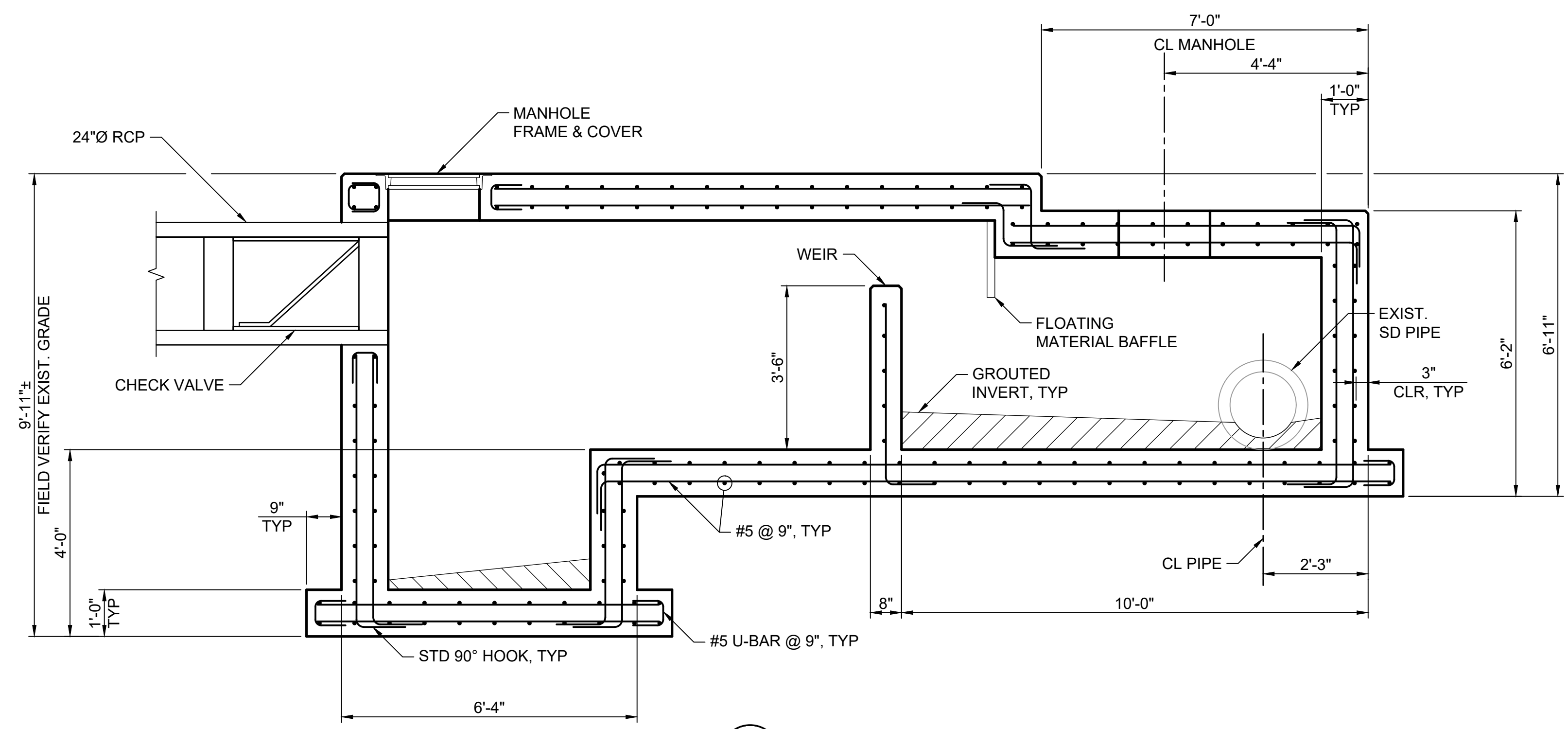

C3
C-501
SECTION
SCALE: 1/2"=1'-0"

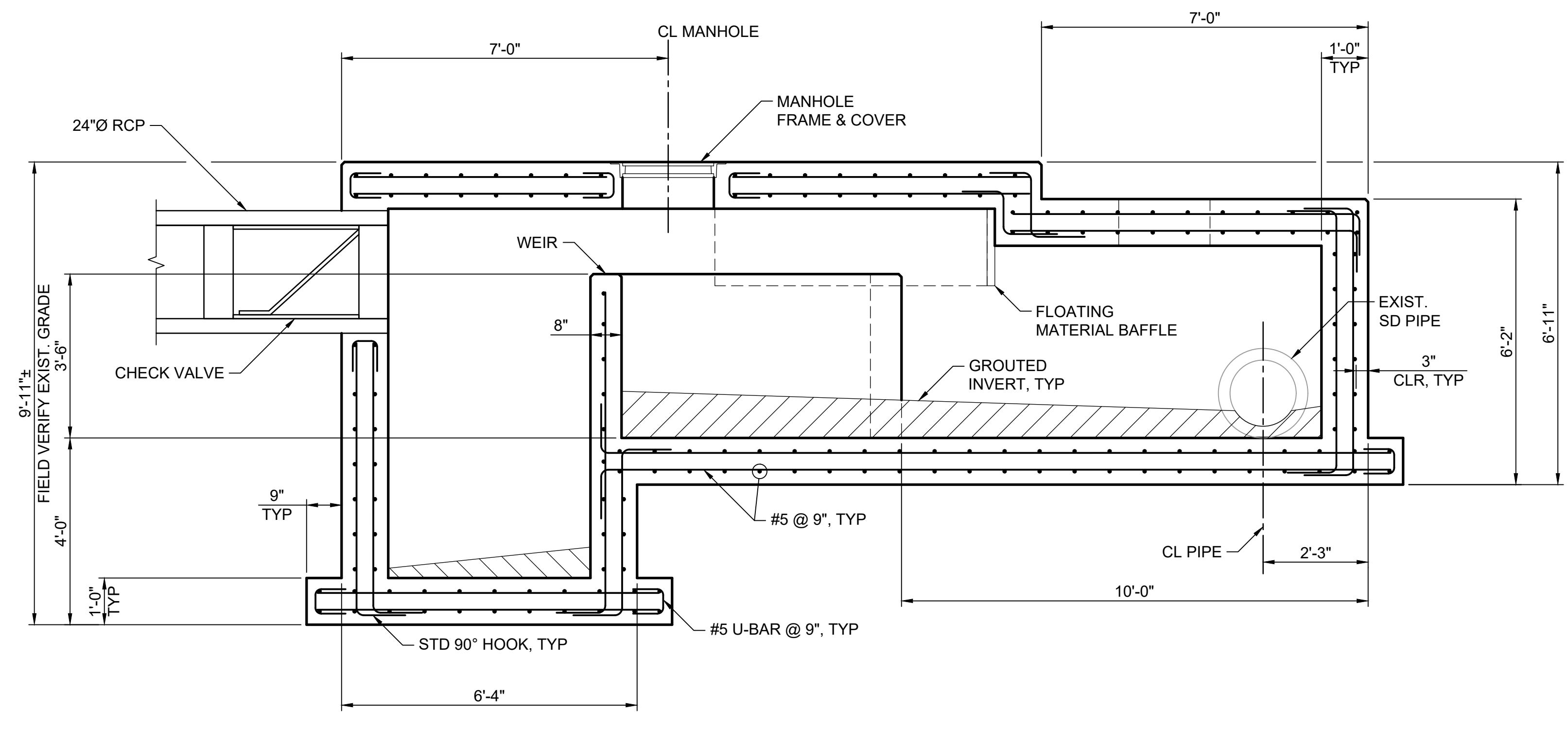

B3
C-501
SECTION
SCALE: 1/2"=1'-0"

NOTES:

- ALL ACCESS COVERS ARE HS-20 RATED.
- ALL STRUCTURES ARE TRAFFIC BEARING.
- THE FLOATING BAFFLE SHALL BE CONSTRUCTED OF FIBERGLASS PLATES AND SHAPES. MINIMUM FLAT PLATE THICKNESS SHALL BE 1/4". THE COMPONENTS SHALL BE PREFABRICATED AND PUT TOGETHER WITH 316L STAINLESS STEEL HARDWARE. ATTACHMENTS TO THE STRUCTURE SHALL UTILIZE 316L STAINLESS STEEL ANCHORS. THE CONTRACTOR SHALL SUBMIT FABRICATION DRAWINGS TO THE ENGINEER FOR REVIEW. THE COMPONENTS WILL HAVE TO BE DEVELOPED SO THE COMPONENTS CAN BE INSERTED INTO THE STRUCTURE THROUGH THE ACCESS MANHOLES.

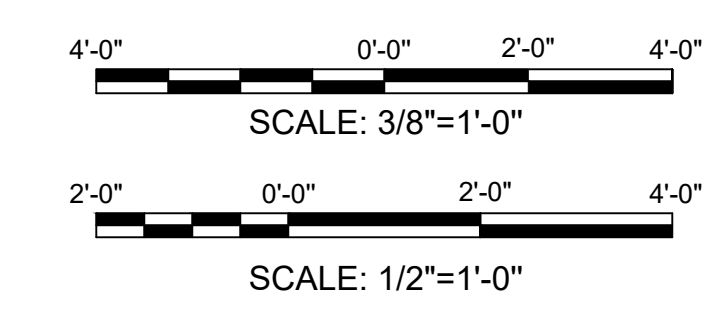

DRAWING SCALES SHOWN BASED ON 30"x42" DRAWING

		301 MAIN ST., SUITE 800 BATON ROUGE, LA 70801 225-336-2075 WWW.MOFFATTNICHOL.COM	
DESIGNED BY: TRR DATE: 26-04-01 REV: 0		CHECKED BY: TRR M&N PROJECT NO: 243137	
DRAWN BY: BDF REVIEWED BY: TRR		DRAWING CODE:	
SUBMITTED BY: TRR		DWG SCALE: AS NOTED PLOT SCALE: 1:1 (ARCH E1)	
MOFFATT & NICHOL		MERCY PARTNERS, LLC 1000 S NORMAN C, FRANCIS PARKWAY NEW ORLEANS, LA 70125	

MERCY HOSPITAL STORM DRAIN SYSTEM		C-501 Sheet 5 of 8
CIVIL DETAILS - SHEET 1		

100% FOR REVIEW
 ISSUED: 2026-04-01
 NOT TO BE USED FOR CONSTRUCTION

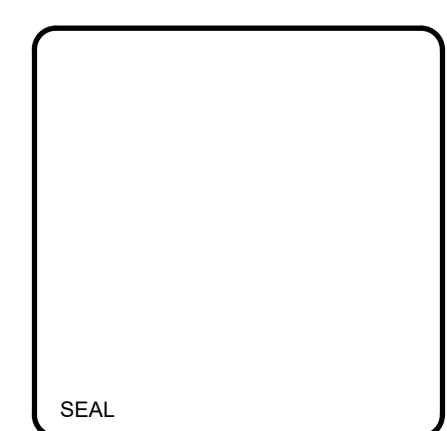

File: P:\BR\2413720\CADD_Archive_Sheets\24137C-501.dwg, Printed: 4/1/2026 3:43 PM by FORD, BRAMAN, Sheet: 28/2026 1:21 PM by BCFORD

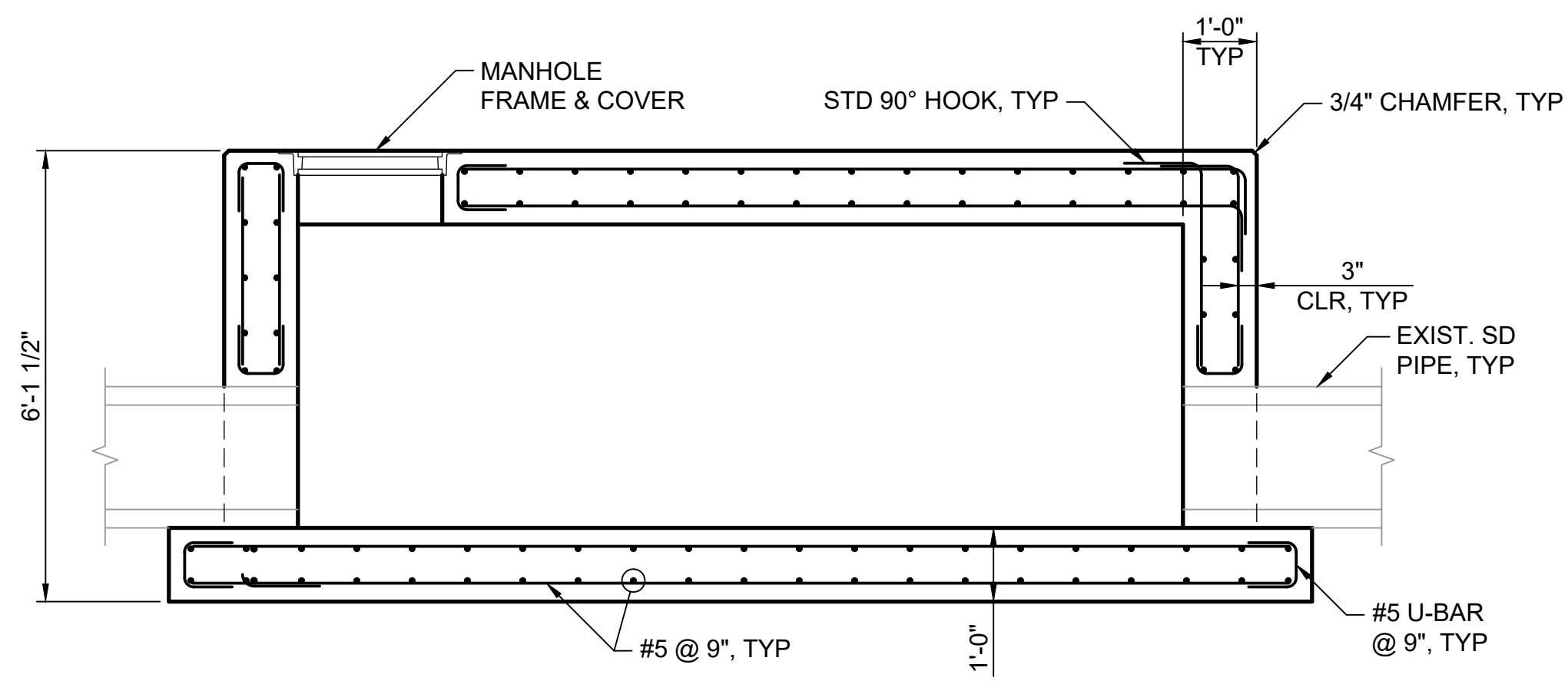

D1 SECTION
C-502 SCALE: 1/2"=1'-0"

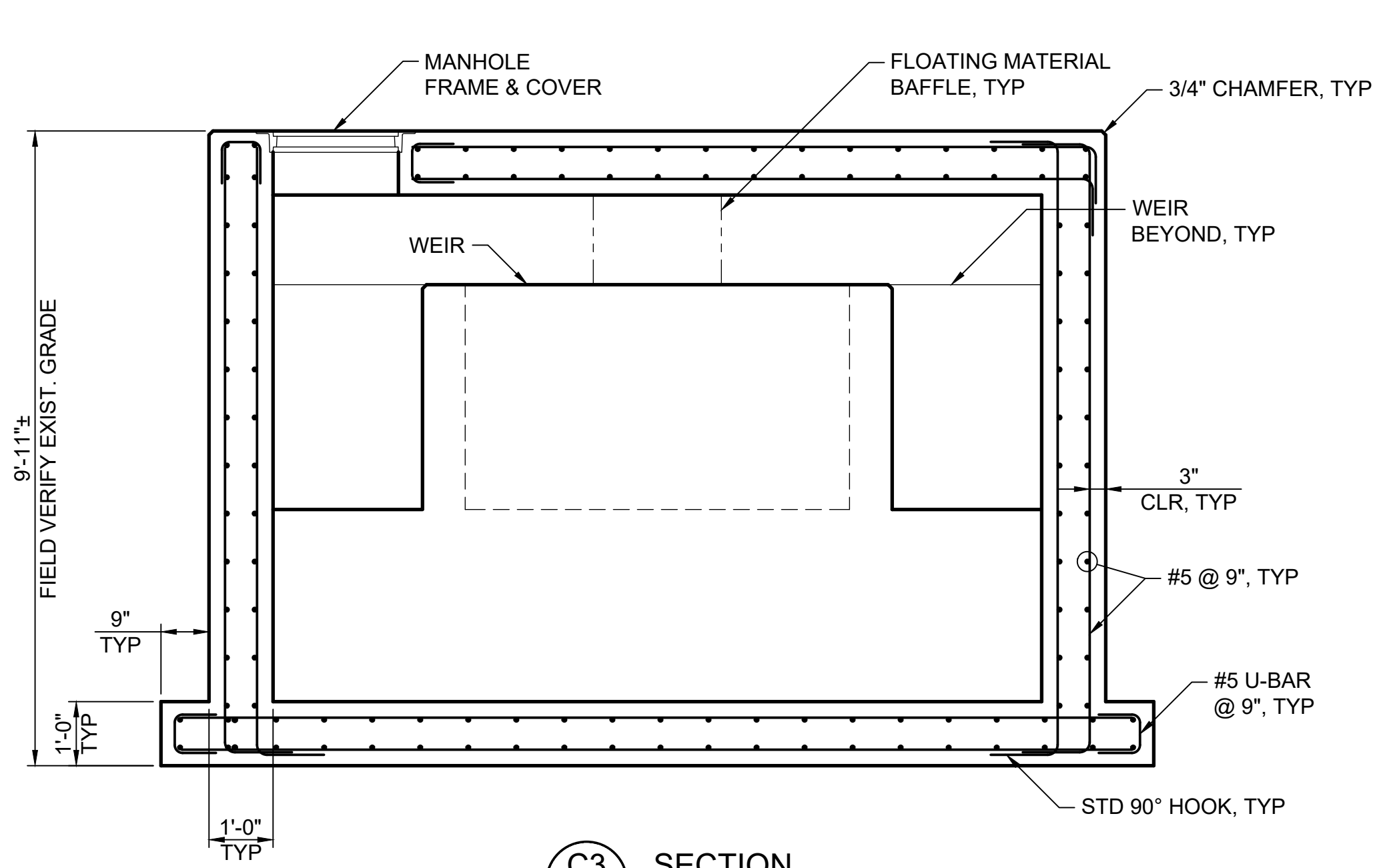

C3 SECTION
C-502 SCALE: 1/2"=1'-0"

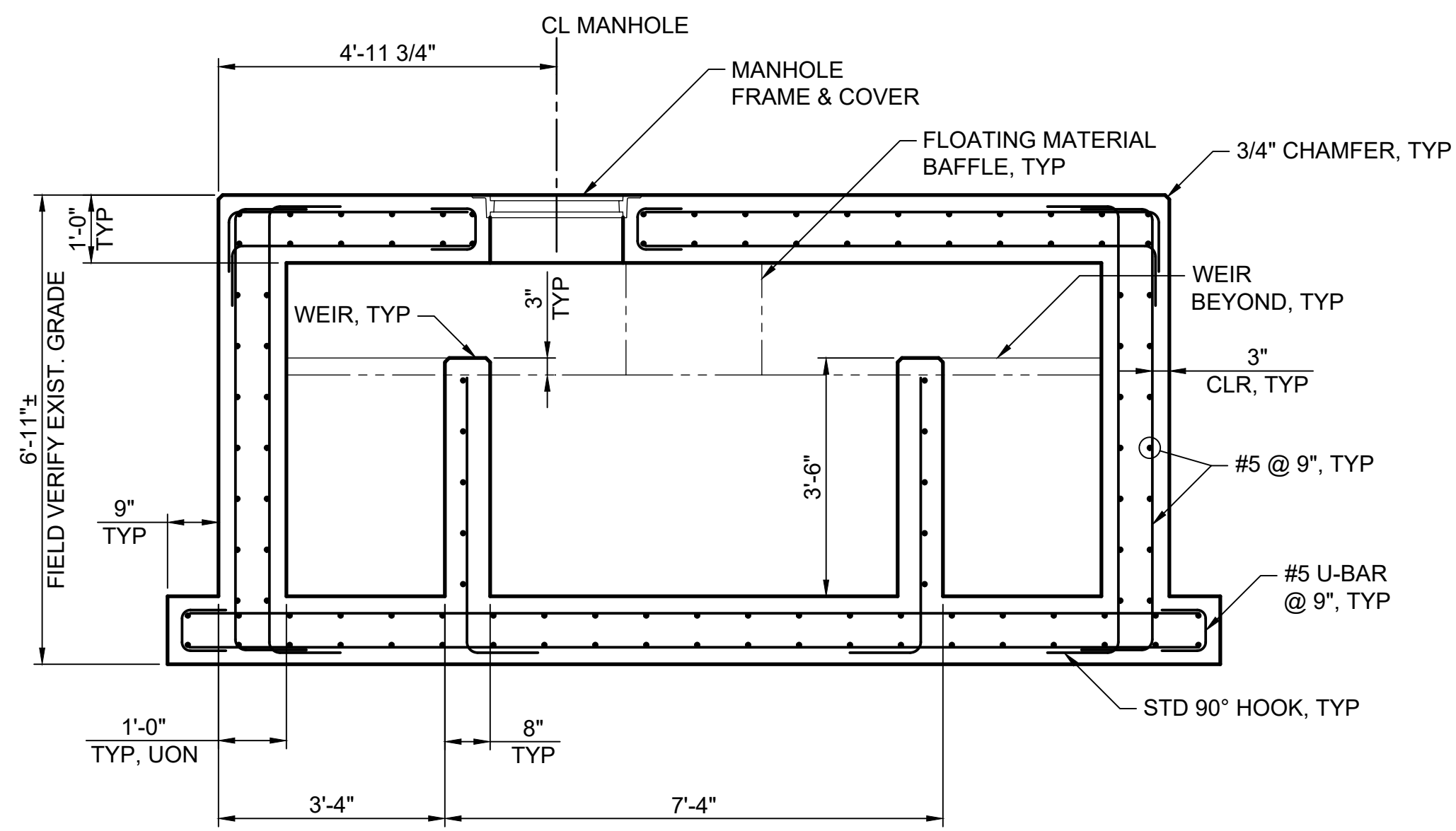

B1 SECTION
C-502 SCALE: 1/2"=1'-0"

NOTES:

1. ALL ACCESS COVERS ARE HS-20 RATED.
2. ALL STRUCTURES ARE TRAFFIC BEARING.

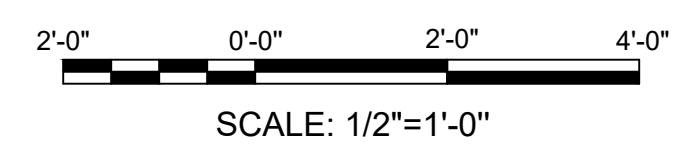

SCALE: 1/2"=1'-0"

DRAWING SCALES SHOWN BASED ON 30"x42" DRAWING

		301 MAIN ST., SUITE 800 BATON ROUGE, LA 70801 225-336-2075 WWW.MOFFATTNICHOL.COM	
MERCY PARTNERS, LLC 1000 S NORMAN C, FRANCIS PARKWAY NEW ORLEANS, LA 70125		Mark	Description
Date: 26-04-01	Rev: 0	Size	Appr.

Designed by: TRR	Date: 26-04-01	Rev: 0
Drawn by: BDF	Checked by: TRR	MAN Project No: 243137
Reviewed by: TRR	Drawing code:	
Submitted by: MOFFATT & NICHOL	Dwg Scale: AS NOTED	Plot scale: 1:1 (ARCH E1)

**MERCY HOSPITAL
STORM DRAIN SYSTEM**

CIVIL DETAILS - SHEET 2

Sheet Reference Number:
C-502
Sheet 6 of 8

100% FOR REVIEW
ISSUED: 2026-04-01
NOT TO BE USED FOR CONSTRUCTION

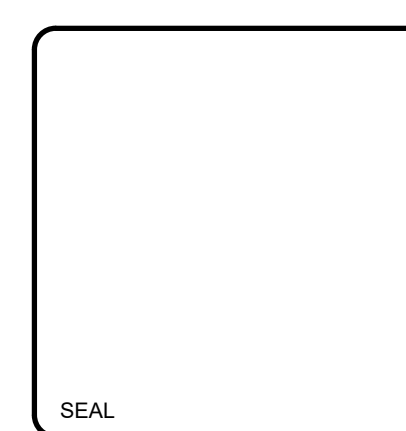

File: P:\BRD\2413720\CADD_Aerial_Sheets\24137C-502_Plot.dwg, Plotter: #1/2026 3:43 PM by FORD, BRANN, Saved: 2/20/2026 1:22 PM by FORD

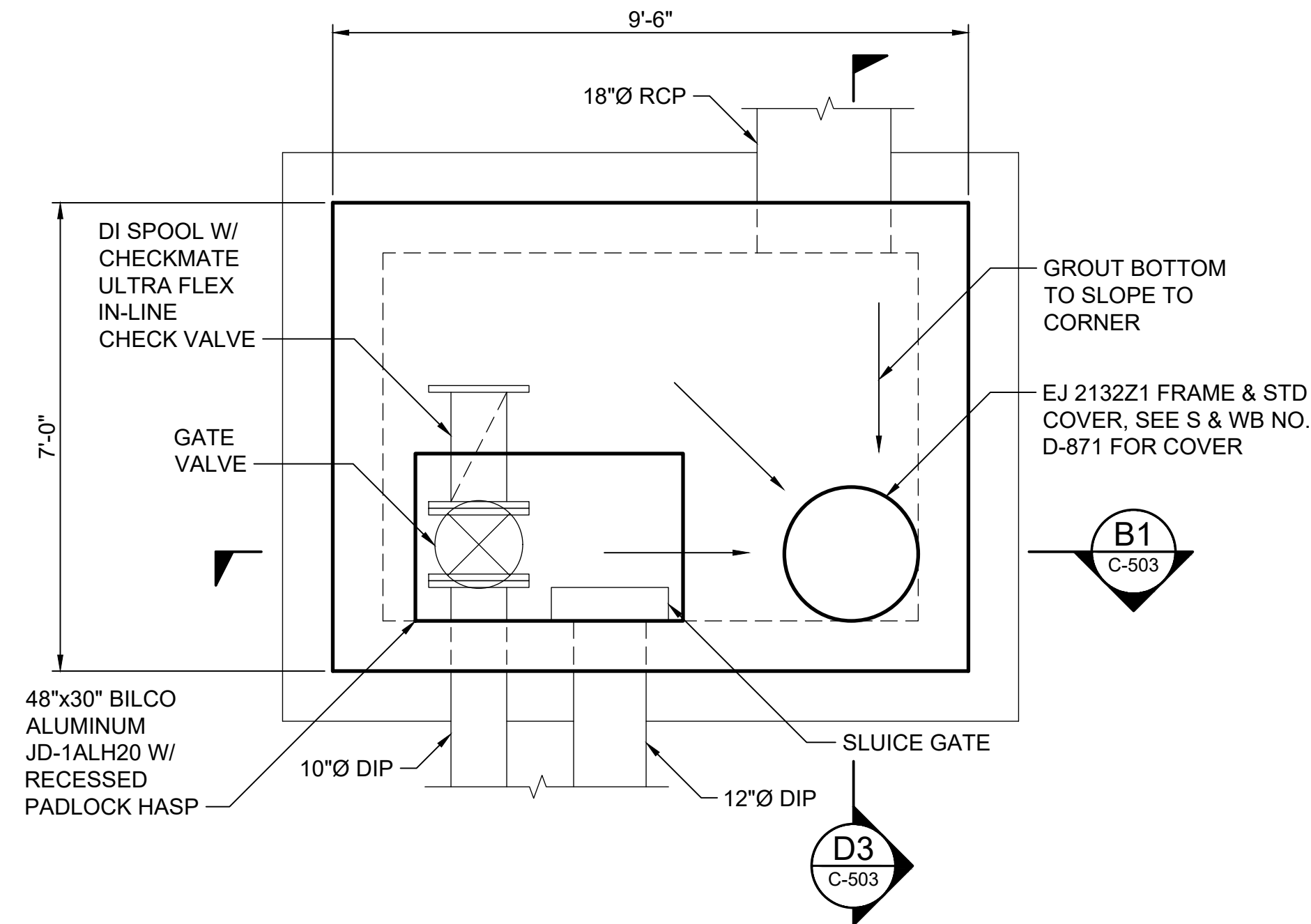

D1 OUTLET CONTROL BOX
C-102 SCALE: 1/2"=1'-0"

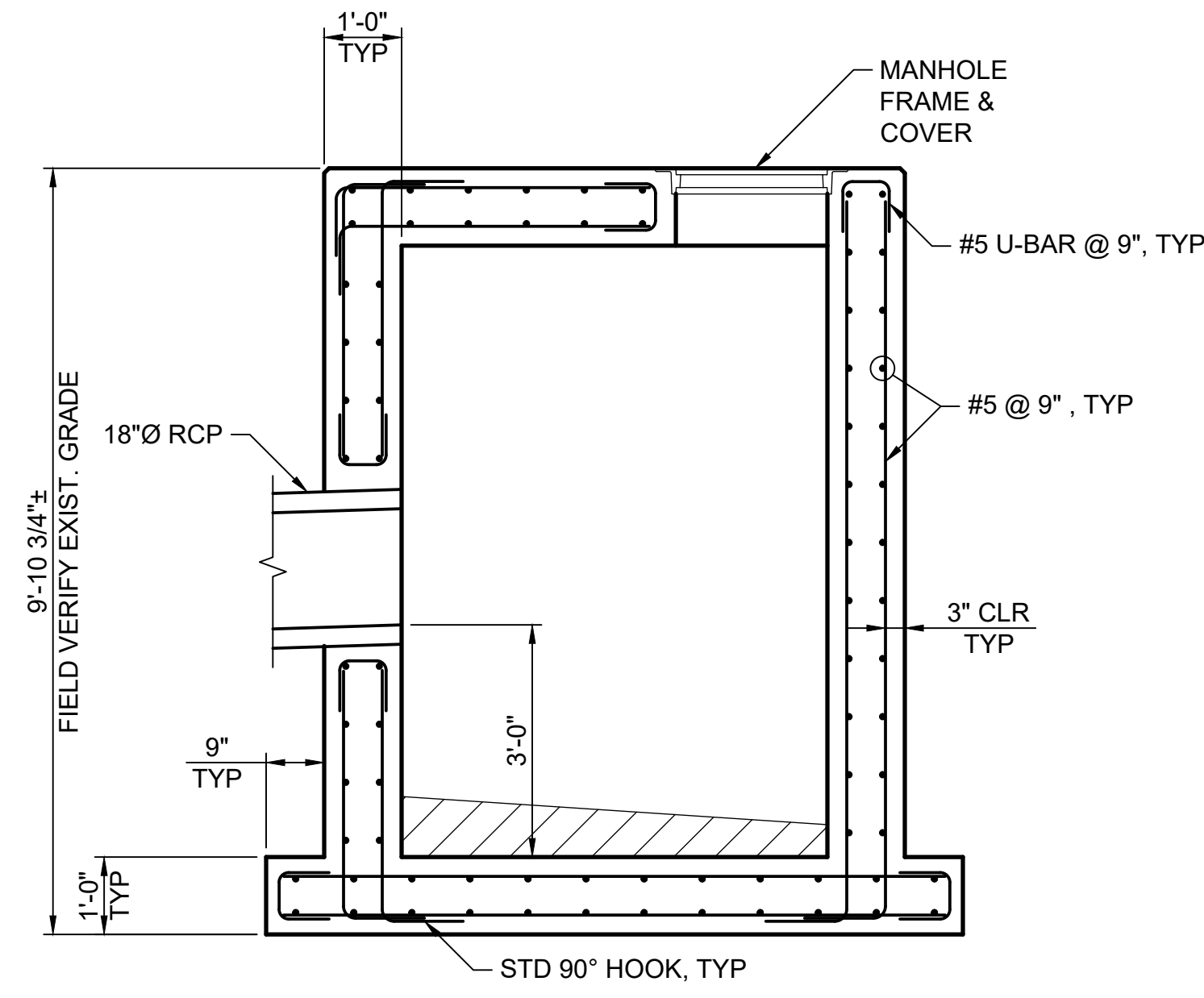

D3 SECTION
C-503 SCALE: 1/2"=1'-0"

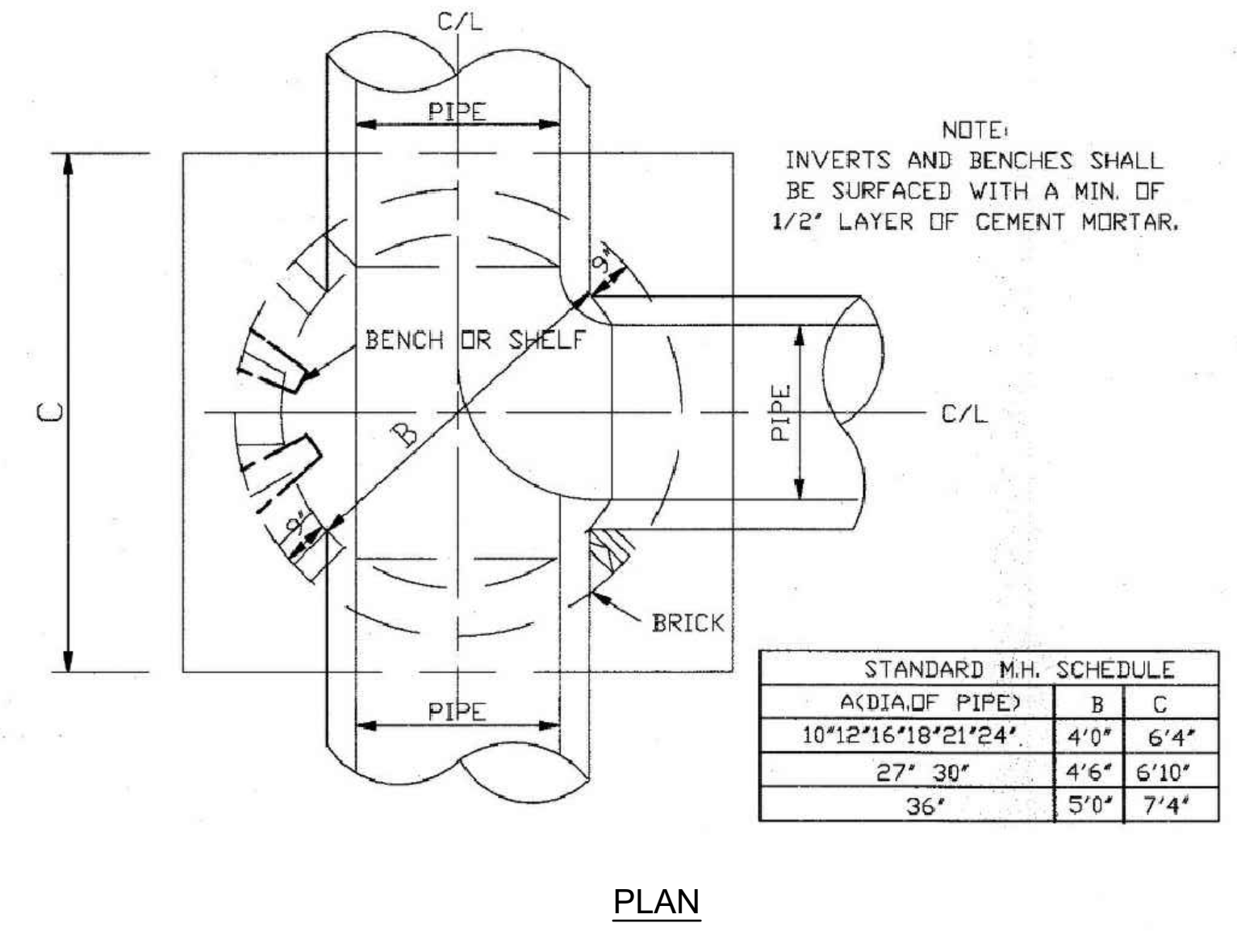

PLAN

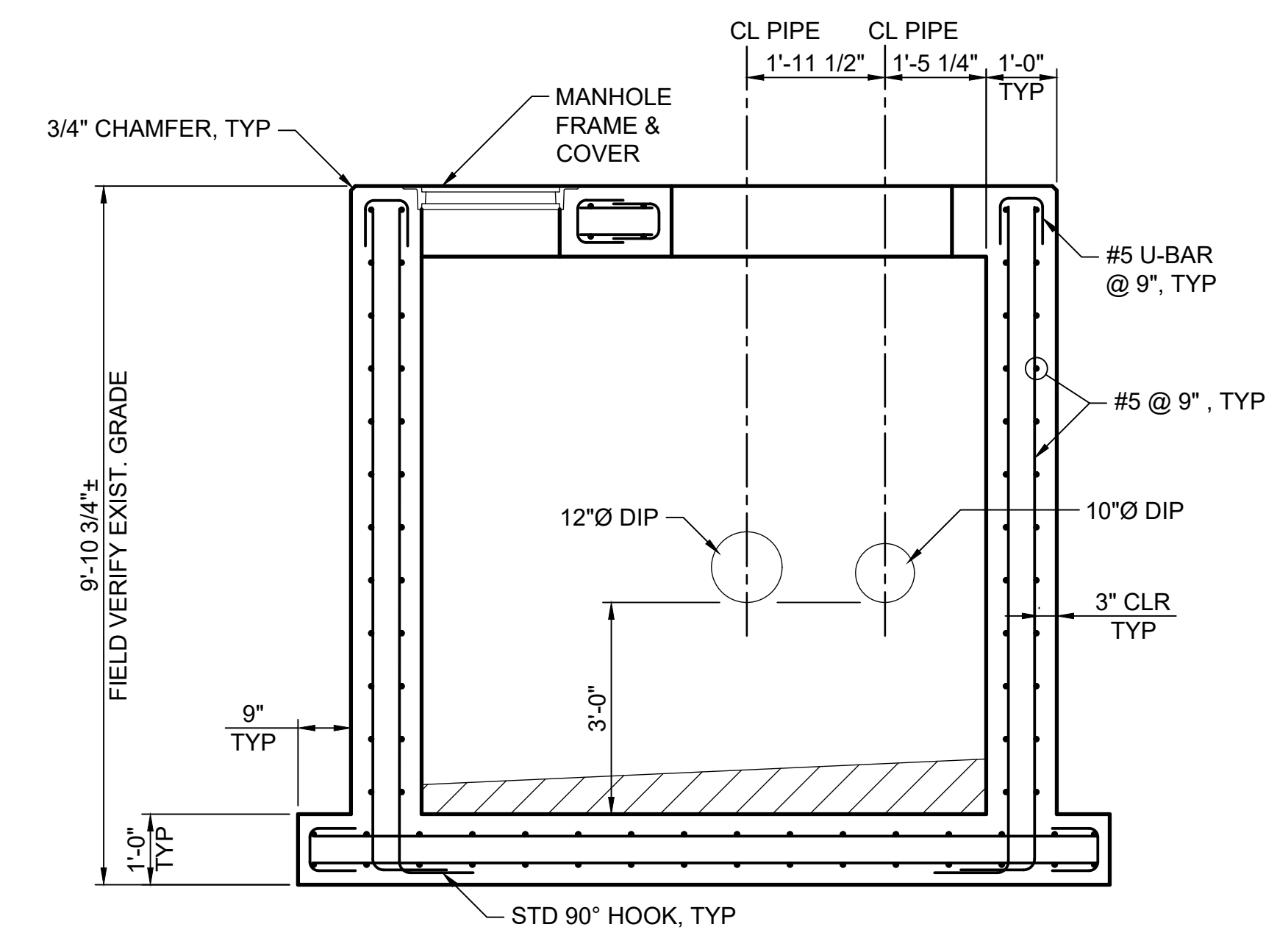

B1 SECTION
C-503 SCALE: 1/2"=1'-0"

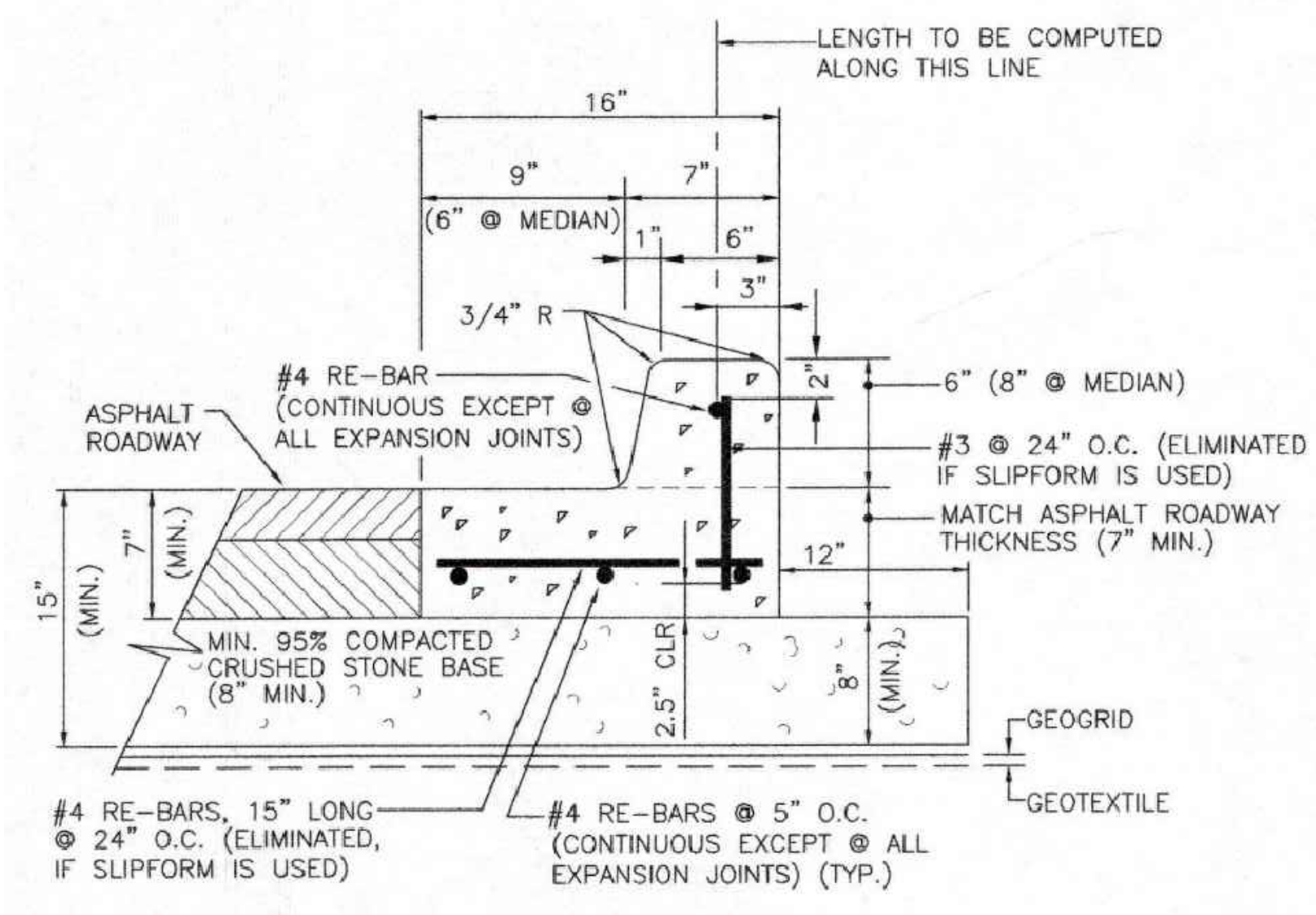

B3 BARRIER CURB AND GUTTER BOTTOM
C-101 NOT TO SCALE

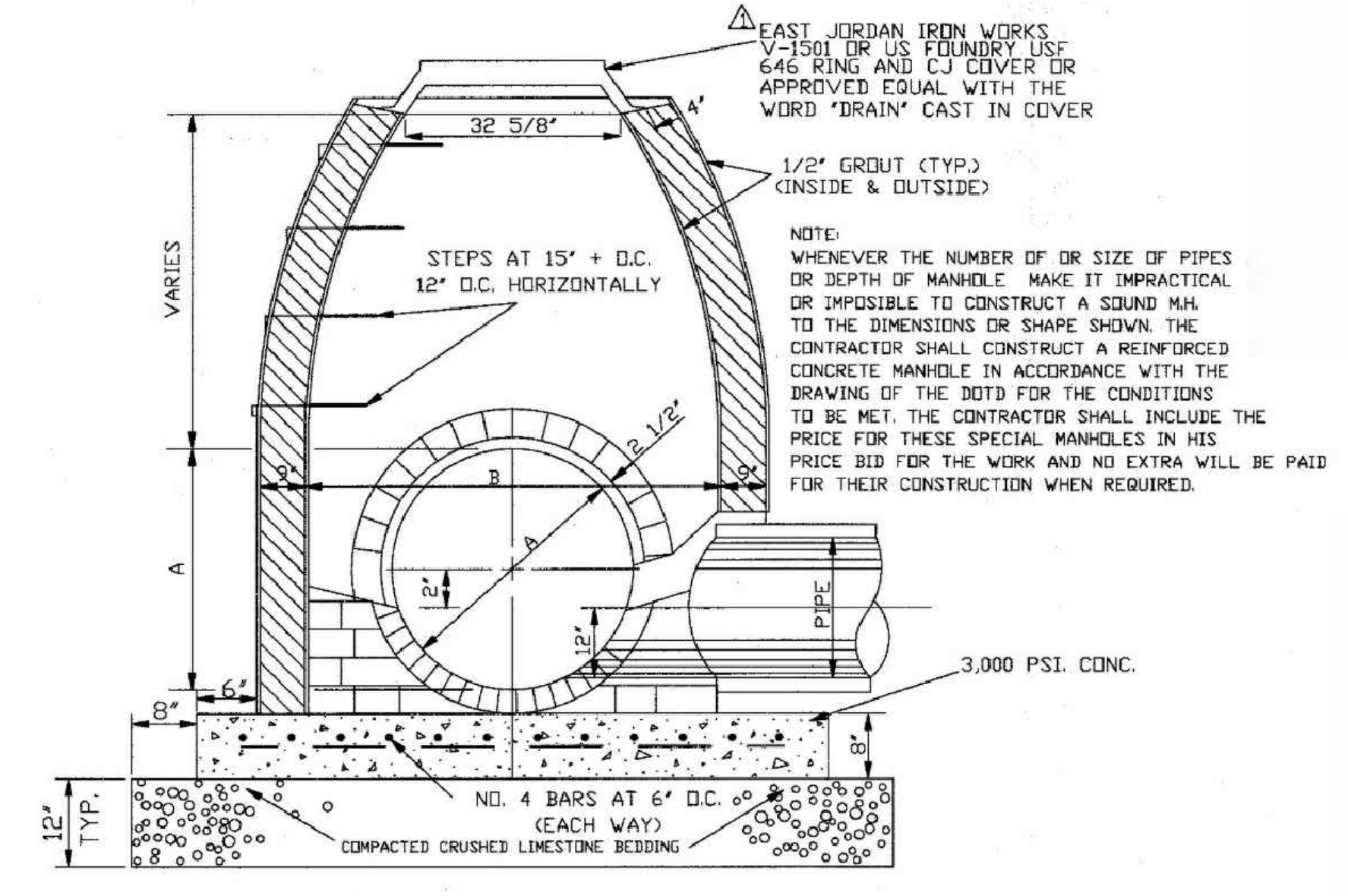

SECTION

B5 DRAINAGE MANHOLE
C-102 NOT TO SCALE

NOTES:

1. ALL ACCESS COVERS ARE HS-20 RATED.
2. ALL STRUCTURES ARE TRAFFIC BEARING.

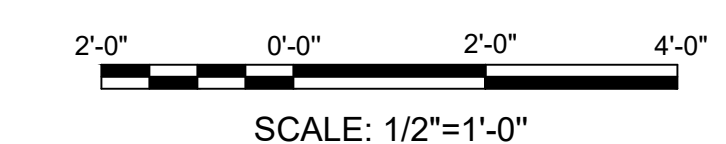

DRAWING SCALES SHOWN BASED ON 30"X42" DRAWING

		301 MAIN ST., SUITE 800 BATON ROUGE, LA 70801 225-336-2075 WWW.MOFFATTNICHOL.COM									
MERCY PARTNERS, LLC 1000 S NORMAN C, FRANCIS PARKWAY NEW ORLEANS, LA 70125		<table border="1"> <thead> <tr> <th>Mark</th> <th>Description</th> <th>Date</th> <th>Appr.</th> </tr> </thead> <tbody> <tr> <td> </td> <td> </td> <td> </td> <td> </td> </tr> </tbody> </table>		Mark	Description	Date	Appr.				
Mark	Description	Date	Appr.								

Designed by:	TRR	Date:	26-04-01	Rev:	0
Drawn by:	BDF	Checked by:	TRR	M&N Project No:	243137
Reviewed by:	TRR	Drawing code:			
Submitted by:		Dwg Scale:	AS NOTED		
MOFFATT & NICHOL		Plot scale:	1:1 (ARCH E1)		

**MERCY HOSPITAL
STORM DRAIN SYSTEM**

CIVIL DETAILS - SHEET 3

Sheet Reference Number:
C-503
Sheet 7 of 8

100% FOR REVIEW
ISSUED: 2026-04-01
NOT TO BE USED FOR CONSTRUCTION

SEAL

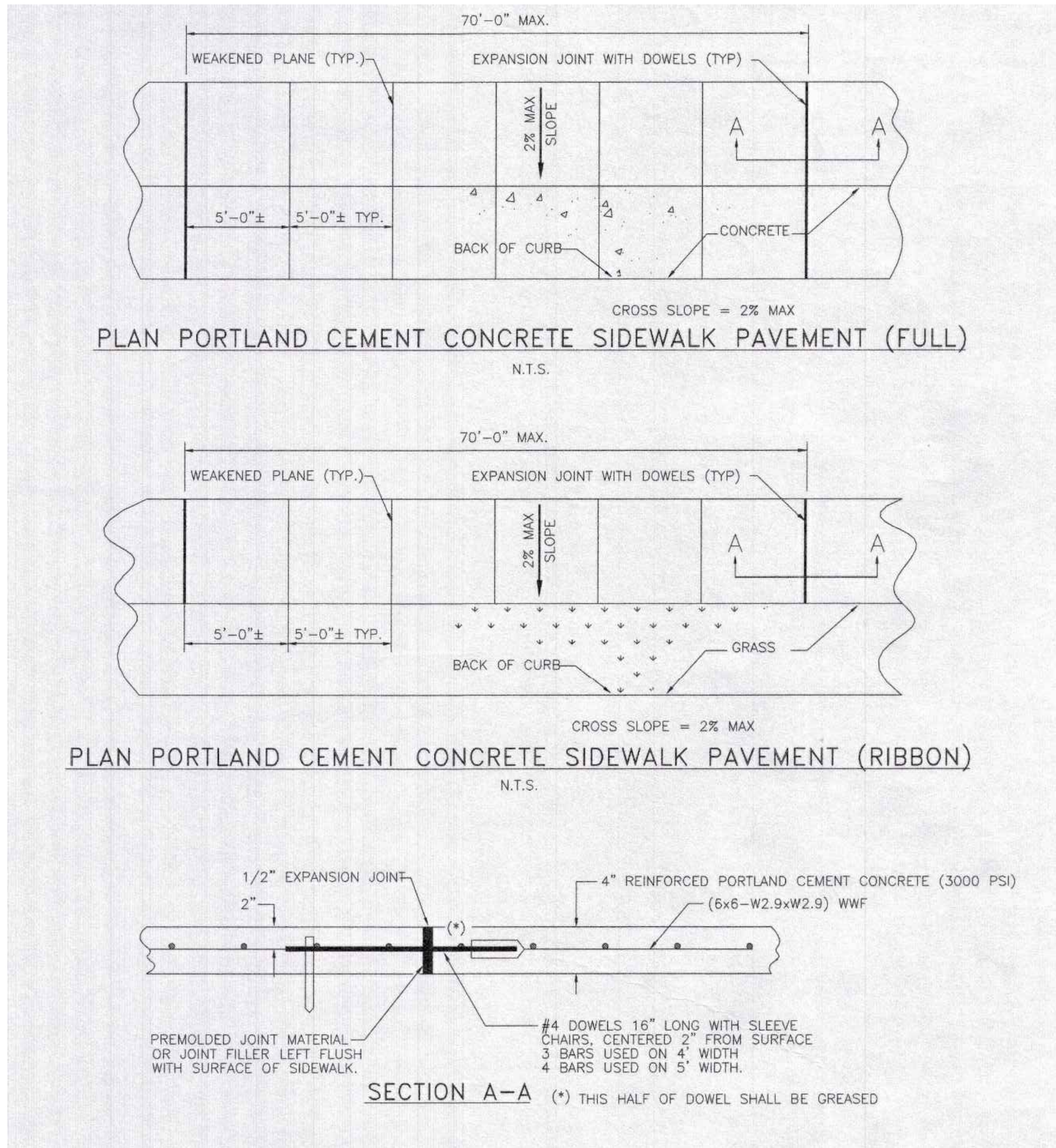

B1 CONCRETE SIDEWALK
C-504 NOT TO SCALE

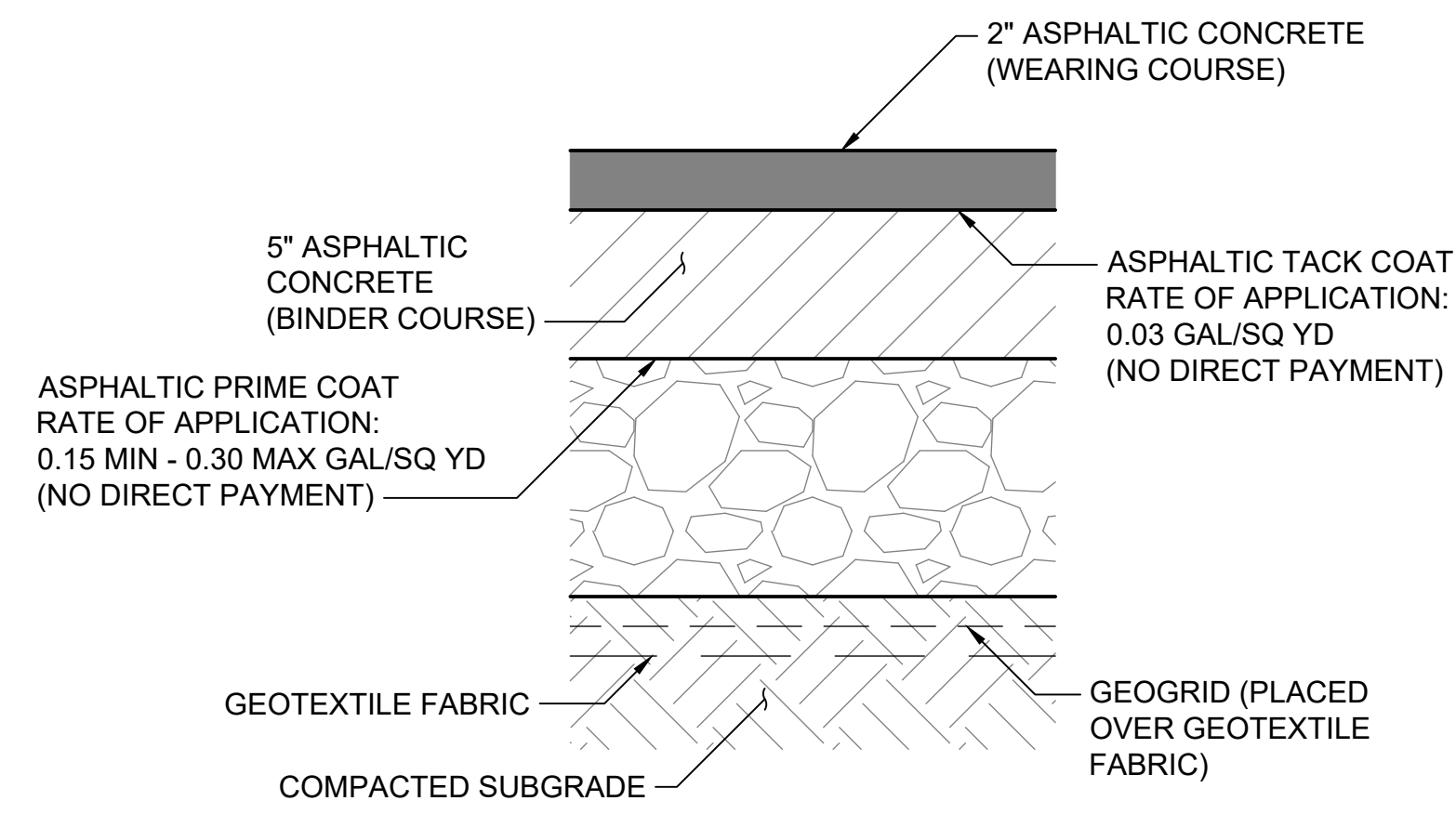

A1 ASPHALT PAVEMENT PATCH
C-101 NOT TO SCALE

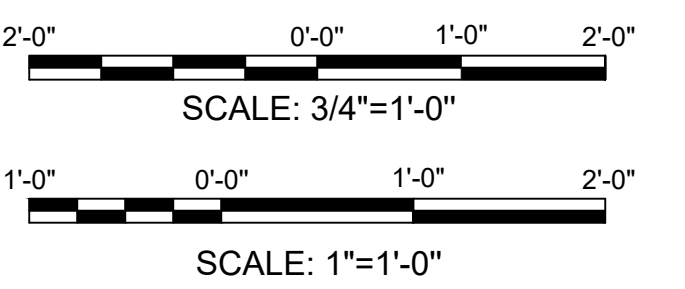

DRAWING SCALES SHOWN BASED ON 30"x42" DRAWING

		301 MAIN ST., SUITE 800 BATON ROUGE, LA 70801 225-336-2075 WWW.MOFFATTNICHOL.COM																																													
MERCY PARTNERS, LLC 1000 S NORMAN C, FRANCIS PARKWAY NEW ORLEANS, LA 70125		<table border="1"> <thead> <tr> <th>Mark</th> <th>Description</th> <th>Date</th> <th>Appr.</th> </tr> </thead> <tbody> <tr><td> </td><td> </td><td> </td><td> </td></tr> <tr><td> </td><td> </td><td> </td><td> </td></tr> <tr><td> </td><td> </td><td> </td><td> </td></tr> <tr><td> </td><td> </td><td> </td><td> </td></tr> <tr><td> </td><td> </td><td> </td><td> </td></tr> <tr><td> </td><td> </td><td> </td><td> </td></tr> <tr><td> </td><td> </td><td> </td><td> </td></tr> <tr><td> </td><td> </td><td> </td><td> </td></tr> <tr><td> </td><td> </td><td> </td><td> </td></tr> <tr><td> </td><td> </td><td> </td><td> </td></tr> </tbody> </table>		Mark	Description	Date	Appr.																																								
Mark	Description	Date	Appr.																																												

Designed by:	TRR	Date:	26-04-01	Rev:	0
Drawn by:	BDF	Checked by:	TRR	MAN Project No:	243137
Reviewed by:	TRR	Drawing code:			
Submitted by:		Dwg Scale:	AS NOTED		
MOFFATT & NICHOL		Plot scale:	1:1 (ARCH E1)		

**MERCY HOSPITAL
STORM DRAIN SYSTEM**

CIVIL DETAILS - SHEET 4

Sheet Reference Number:
C-504
Sheet 8 of 8

**100% FOR REVIEW
ISSUED: 2026-04-01
NOT TO BE USED FOR CONSTRUCTION**

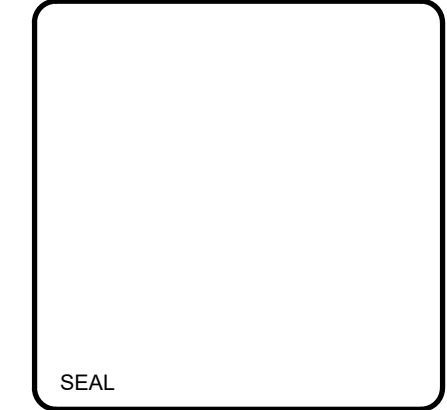

File: P:\BR\24113720\CADD_Active_Sheets\241137C-504_Plot.dwg: 4/1/2026 3:44 PM by: FORD, BRAMAN, Steven: 3/31/2026 6:37 PM by: BFOOD

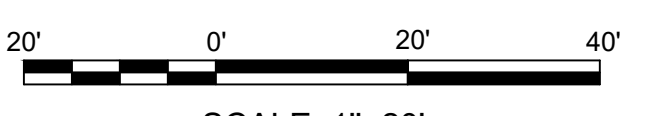
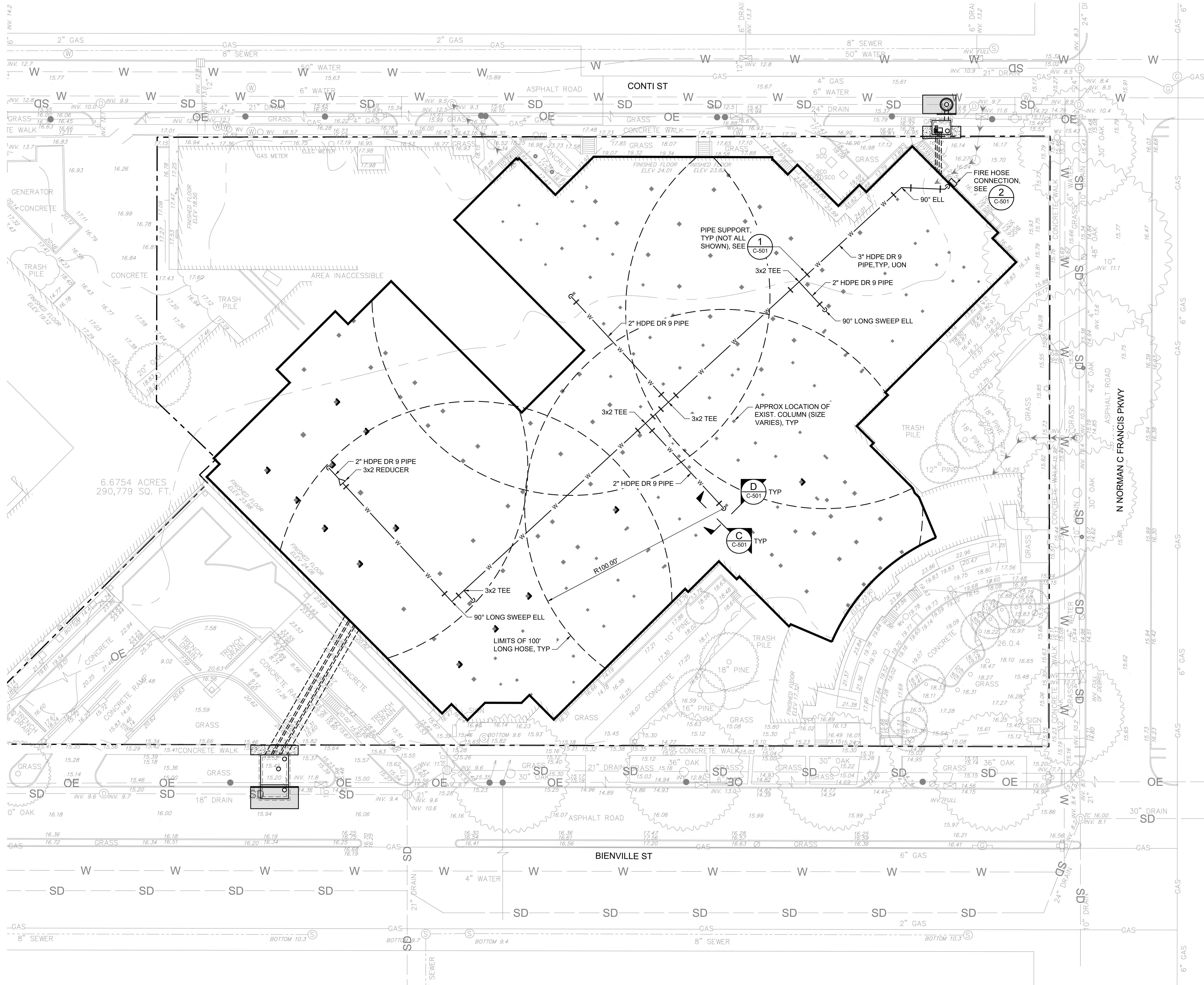
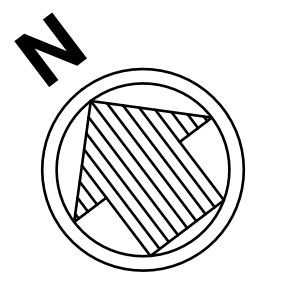

SCALE: 1"=20'
DRAWING SCALES SHOWN BASED ON 30"x42" DRAWING

		301 MAIN ST., SUITE 800 BATON ROUGE, LA 70801 225-336-2075 WWW.MOFFATTNICHOL.COM																					
MERCY PARTNERS, LLC 1000 S NORMAN C, FRANCIS PARKWAY NEW ORLEANS, LA 70125		<table border="1"> <thead> <tr> <th>Mark</th> <th>Description</th> <th>Date</th> <th>Appr.</th> </tr> </thead> <tbody> <tr><td> </td><td> </td><td> </td><td> </td></tr> <tr><td> </td><td> </td><td> </td><td> </td></tr> <tr><td> </td><td> </td><td> </td><td> </td></tr> <tr><td> </td><td> </td><td> </td><td> </td></tr> </tbody> </table>		Mark	Description	Date	Appr.																
Mark	Description	Date	Appr.																				

Designed by:	TRR	Date:	26-04-01	Rev:	0
Drawn by:	BDF	Checked by:	TRR	MAN Project No:	243137
Reviewed by:	TRR	Drawing code:			
Submitted by:		Dwg Scale:	AS NOTED		
		Plot scale:	1:1 (ARCH E1)		

**MERCY HOSPITAL
STORM DRAIN SYSTEM**

**DETENTION BASIN WASH
SYSTEM - PLAN**

Sheet
Reference
Number:
C-101
Sheet of

**100% FOR REVIEW
ISSUED: 2026-04-01
NOT TO BE USED FOR CONSTRUCTION**

File: P:\BR\2413\20\CA\DD - Active\Sheet\Wash System\243137C-101.dwg, Printed: 4/1/2026, 2:35 PM by: FORD, BRAM, Sheet: 4/1/2026, 12:29 PM by: BFOOD

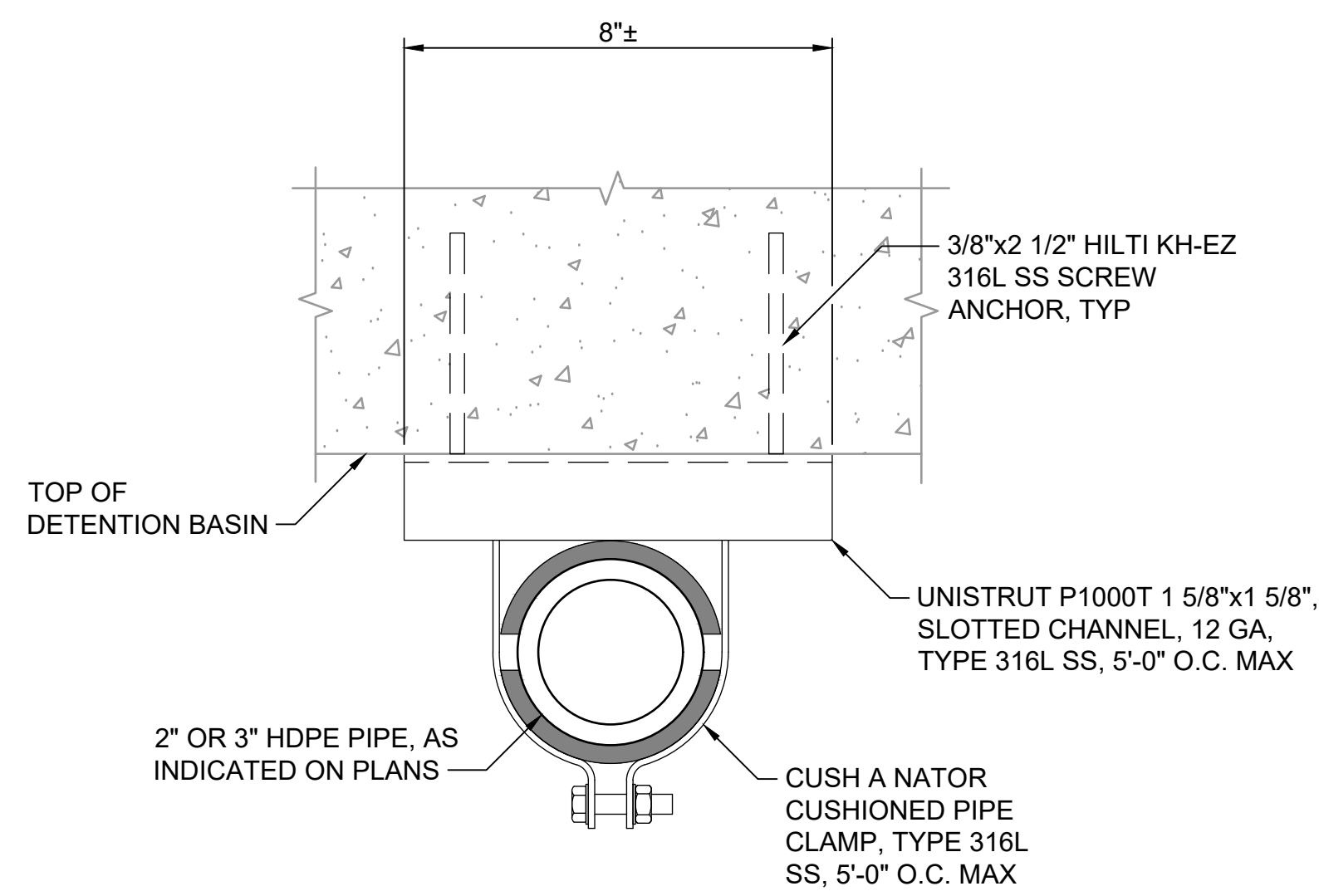

1 PIPE SUPPORT
C-101 NOT TO SCALE

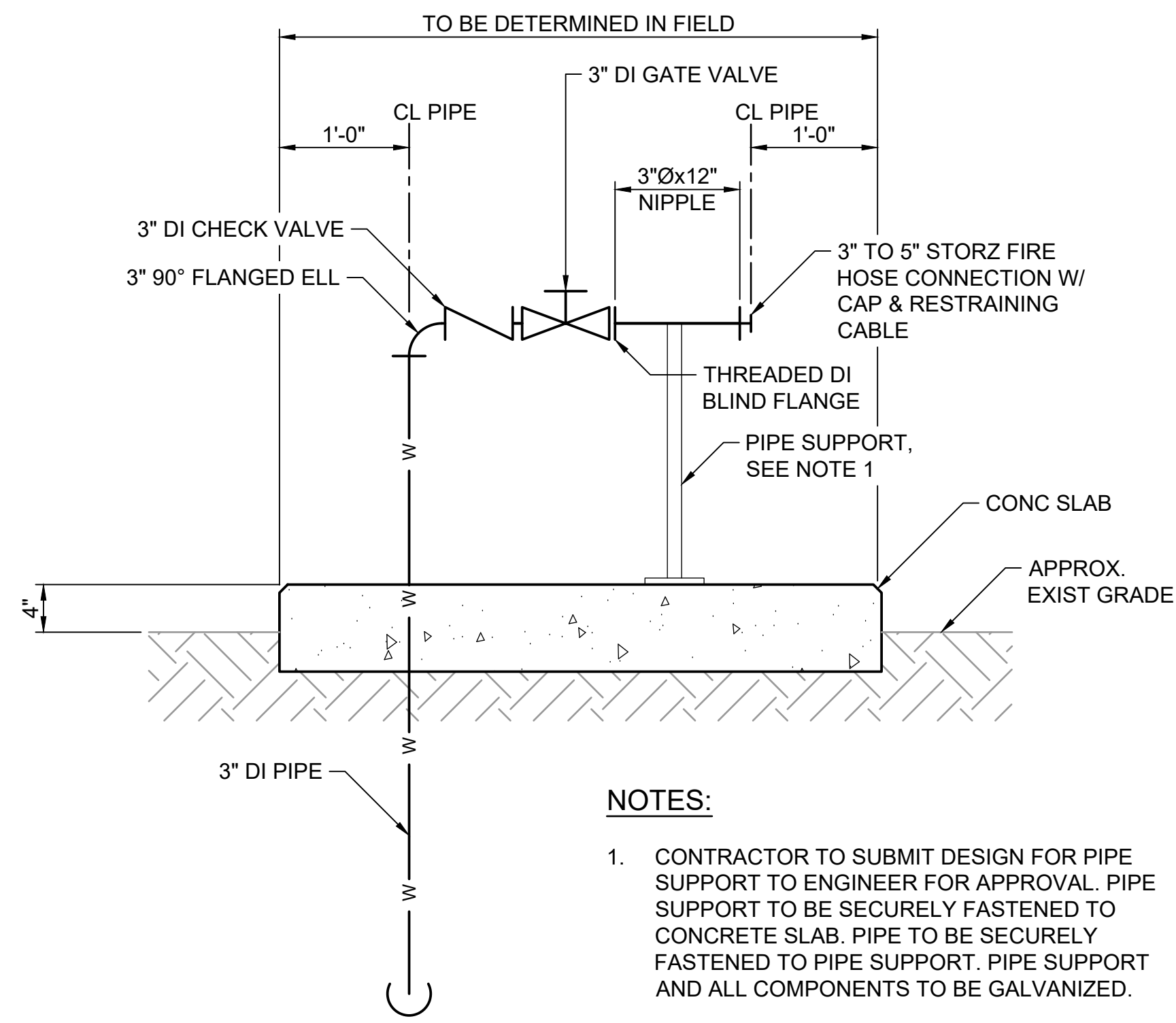

- NOTES:**
- CONTRACTOR TO SUBMIT DESIGN FOR PIPE SUPPORT TO ENGINEER FOR APPROVAL. PIPE SUPPORT TO BE SECURELY FASTENED TO CONCRETE SLAB. PIPE TO BE SECURELY FASTENED TO PIPE SUPPORT. PIPE SUPPORT AND ALL COMPONENTS TO BE GALVANIZED.
 - ALL ABOVE GROUND PIPING AND VALVES TO BE PAINTED BLACK WITH A HIGH GLOSS PAINT.

B SECTION
C-501 SCALE: 1"=1'-0"

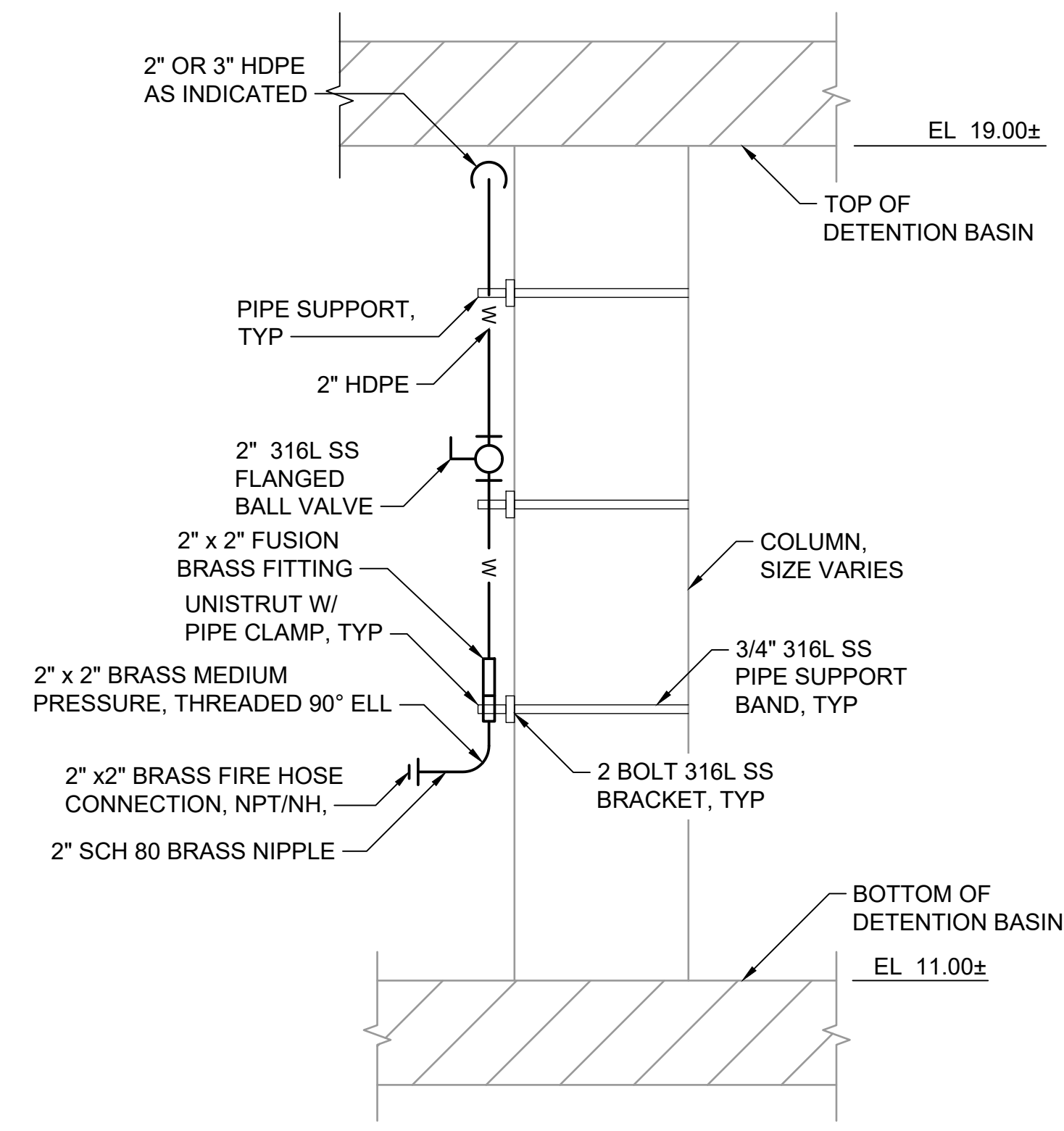

D SECTION
C-101 SCALE: 3/4"=1'-0"

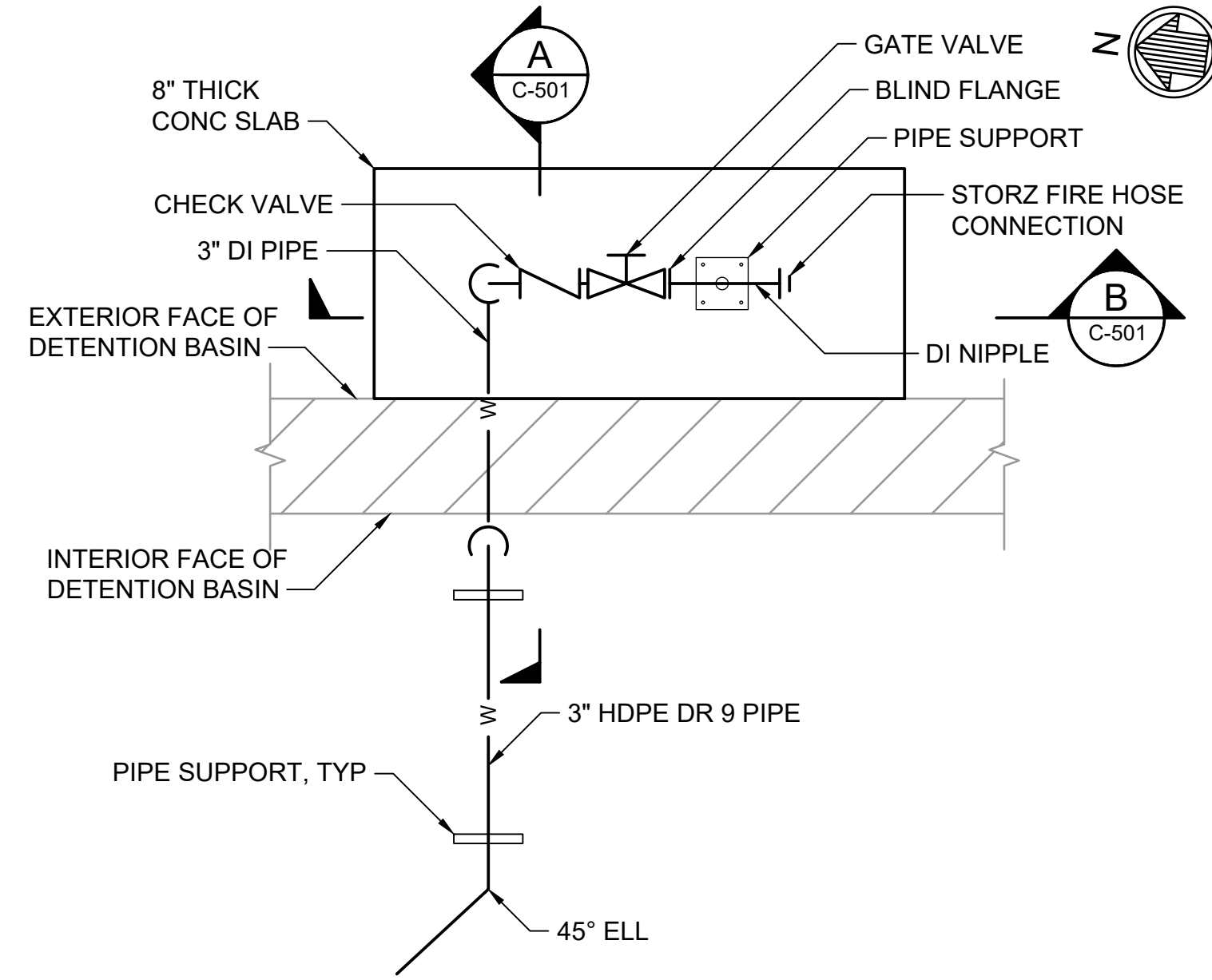

2 FIRE HOSE CONNECTION
C-101 SCALE: 3/4"=1'-0"

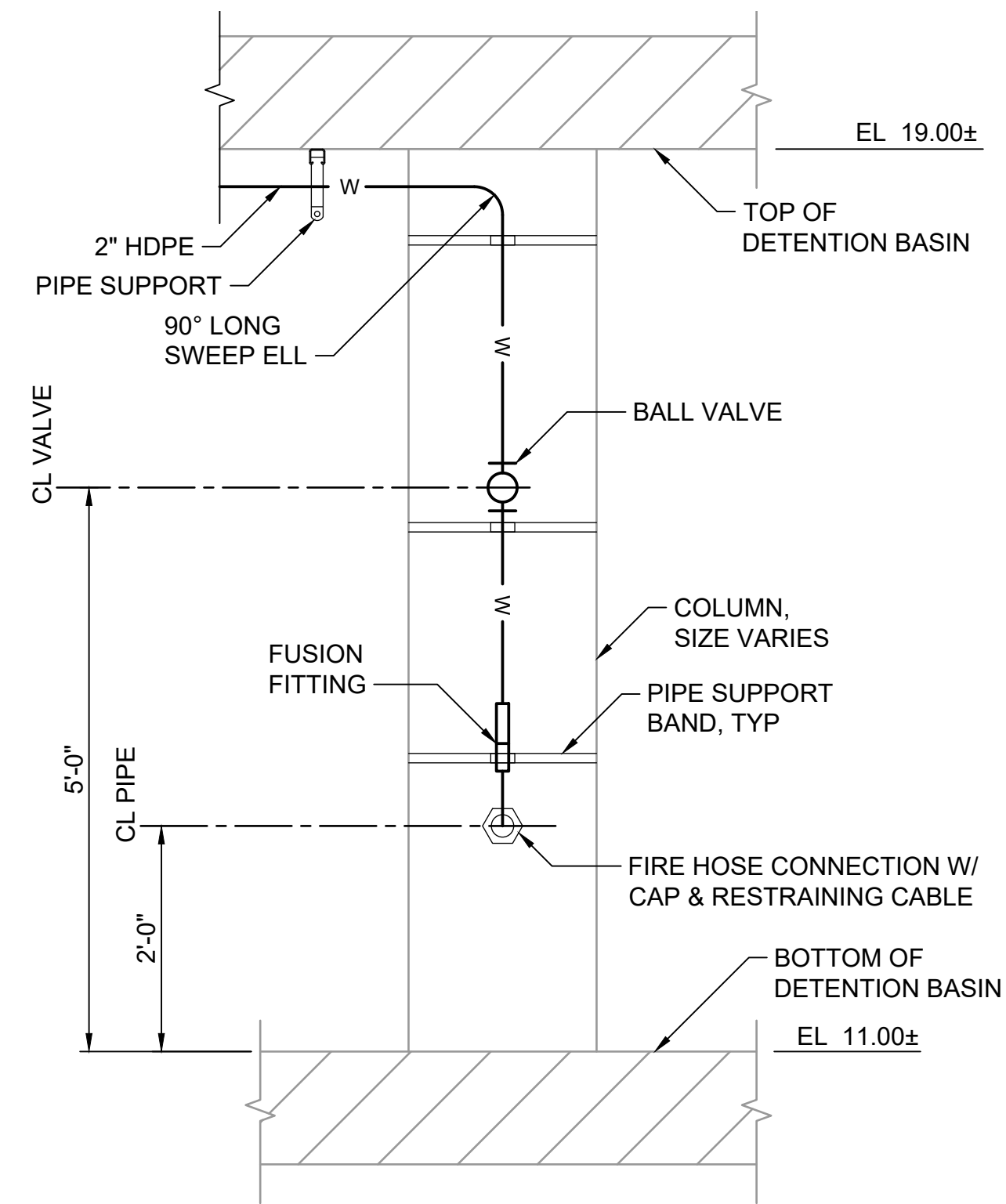

C SECTION
C-101 SCALE: 3/4"=1'-0"

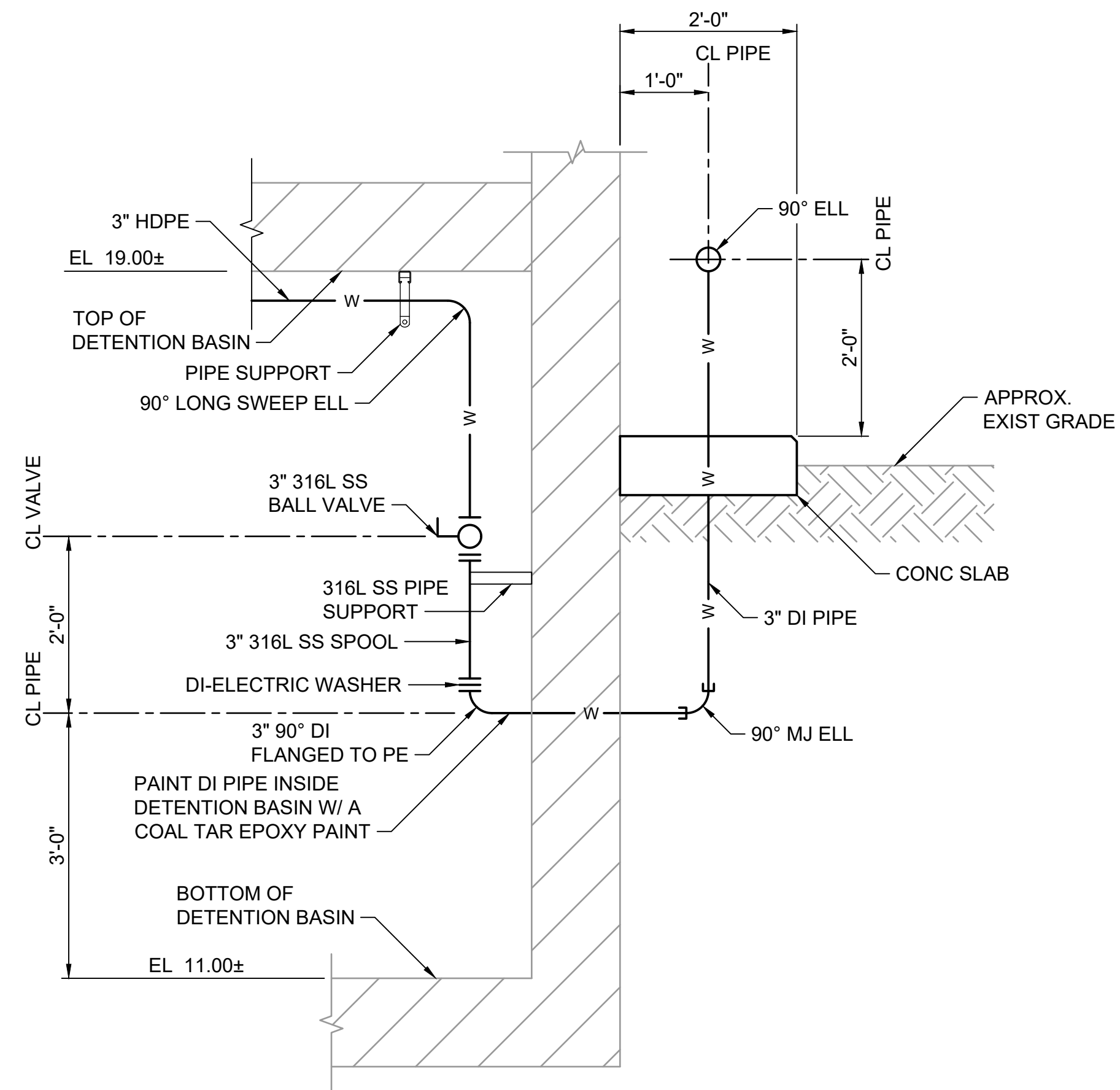

A SECTION
C-501 SCALE: 3/4"=1'-0"

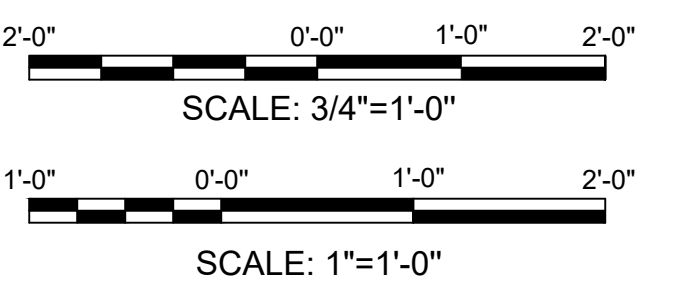

DRAWING SCALES SHOWN BASED ON 30"x42" DRAWING

		301 MAIN ST., SUITE 800 BATON ROUGE, LA 70801 225-336-2075 WWW.MOFFATTNICHOL.COM																	
MERCY PARTNERS, LLC 1000 S NORMAN C. FRANCIS PARKWAY NEW ORLEANS, LA 70125		<table border="1"> <thead> <tr> <th>Mark</th> <th>Description</th> <th>Date</th> <th>Appr.</th> </tr> </thead> <tbody> <tr> <td> </td> <td> </td> <td> </td> <td> </td> </tr> <tr> <td> </td> <td> </td> <td> </td> <td> </td> </tr> <tr> <td> </td> <td> </td> <td> </td> <td> </td> </tr> </tbody> </table>		Mark	Description	Date	Appr.												
Mark	Description	Date	Appr.																

Designed by:	TRR	Date:	26-04-01	Rev:	0
Drawn by:	BDF	Checked by:	TRR	MAN Project No:	243137
Reviewed by:	TRR	Drawing code:			
Submitted by:		Dwg Scale:	AS NOTED		
MOFFATT & NICHOL		Plot scale:	1:1 (ARCH E1)		

**MERCY HOSPITAL
STORM DRAIN SYSTEM**

**DETENTION BASIN WASH
SYSTEM - DETAILS**

Sheet
Reference
Number:
C-501
Sheet of

100% FOR REVIEW
ISSUED: 2026-04-01
NOT TO BE USED FOR CONSTRUCTION

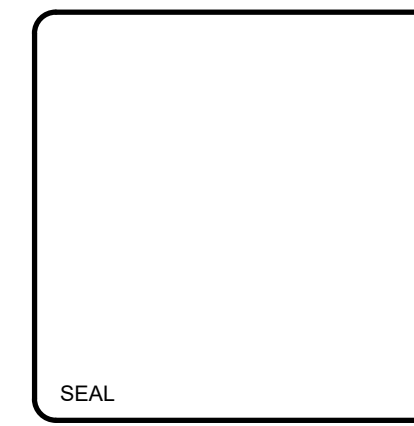

Exhibit D
Payment Schedule

- 1) The first payment, in the amount of \$5,200,000, will be made from the City to Mercy within ten (10) business days after the first sale of the Approved Bonds.

- 2) The second payment, in the amount of \$6,300,000, will be made from the City to Mercy within ten (10) business days after the later of (i) six (6) months after the date Mercy begins demolition of the existing buildings on the Site or (ii) the date Mercy completes demolition of the first floor slab of the former Lindy Boggs Medical Center.

LEASE OF LAND

STATE OF LOUISIANA

BY

PARISH OF ORLEANS

MERCY PARTNERS, LLC

CITY OF NEW ORLEANS

TO

CITY OF NEW ORLEANS

BE IT KNOWN that on the dates set forth below, before us, duly commissioned and qualified Notaries Public in and for the Parish and State aforesaid, and the undersigned competent witnesses, in whose presence this act is passed and executed this day in my office, personally came and appeared:

- (1) **MERCY PARTNERS, LLC**, a Louisiana limited liability company, with a permanent mailing address of 1000 South Norman C. Francis Parkway, New Orleans, LA 70125, herein represented by Paul H. Flower, its Manager, duly authorized to appear herein on its behalf (hereinafter referred to as “Lessor”), and
- (2) **THE CITY OF NEW ORLEANS**, herein represented by Helena N. Moreno, its Mayor, acting under and by virtue of authorization contained in Ordinance No. _____ M.C.S., adopted on _____, 2026, a certified copy of which is annexed hereto and made a part hereof (The City of New Orleans being hereinafter referred to as “City” or “Lessee”).

WHO DECLARED THAT:

For and in consideration of the rents hereinafter stipulated to be paid by Lessee, the parties rights and obligations under that certain Cooperative Endeavor Agreement dated _____, 2026 (the “CEA”), and of the performance and observance by Lessee of the covenants, conditions, and stipulations hereinafter contained, Lessor has leased, let, and demised unto Lessee, its successors and assigns, the following described property belonging to the Lessor (hereinafter collectively referred to as “Leased Premises”):

- A. The subsurface located below the existing first floor building slab, or any replacements thereof or adjustments thereto, of the tract of land described on Exhibit A attached hereto and incorporated herein (the “Retention Area”).
- B. The subsurface portions of Lessor’s property described on Exhibit B attached hereto and incorporated herein (the “Leased Inflow & Outflow Areas”). For clarity, the “Leased Inflow & Outflow Areas” shall not include any property located within the public right-of-way.

Lessee agrees and acknowledges the Leased Premises only includes the subsurface of the land described on Exhibit A and Exhibit B and shall not include the use of the surface of such tracts or any improvements constructed thereon or the right to construct any improvements on the surface of such tracts.

I. TERM

1.1 This Lease shall be binding upon the parties effective as of the date last executed by Lessee and Lessor. The original Term of this Lease shall be ninety-nine (99) years (the “Term”), commencing on the Delivery Date (provided below), with no renewals. As used herein the term “Lease Year” shall mean the twelve (12) month period during the Term commencing on the Delivery Date and each successive twelve (12) month period thereafter included in the Term of this Lease and, if the termination of the Term of this Lease does not coincide with the expiration of such twelve (12) month period, Lease Year shall mean the portion of such twelve (12) month period before such termination.

II. RENT

2.1 This Lease is made for and in consideration of a total payment of \$11,500,000.00 of rent, which is payable in accordance with the payment schedule described in the CEA, and for Lessor's and Lessee's performance of their respective obligations under the CEA.

2.2 Payment of rent shall be made at 1000 South Norman C. Francis Parkway, New Orleans, LA 70125, or at such other place as the Lessor shall designate in writing.

2.3 Intentionally Omitted.

III. USE OF THE LAND

3.1 Lessee is granted the right during the Term of this Lease to the exclusive use the Leased Premises (except as set forth in Section 3.8) for the following (collectively, the "Improvements"):

(a) a storm water drainage retention facility within the Retention Area and (b) inflow and outflow infrastructure within the Leased Inflow & Outflow Area designed to convey stormwater between the Retention Area and the public storm water drainage facilities located outside Lessor's property within the public right-of-way (the "Public Inflow & Outflow Areas"). Lessor shall, at its sole cost and expense, construct the Improvements substantially in accordance with the plans and specifications attached hereto as Exhibit C (the "Plans and Specifications") and otherwise in accordance with all City, State, and Federal laws, ordinances, codes, and regulations. No material changes (each, a "Change") may be made to the Plans and Specifications without the prior written consent of Lessee, which consent shall not be unreasonably conditioned, delayed or withheld. Within fifteen (15) days following receipt of Lessor's proposed Change, which request must clearly show the requested Change, Lessee shall deliver to Lessor its written approval or rejection thereof. If Lessee fails to provide any such approval or rejection within said 15-day period, Lessor's proposed Change shall be deemed approved by Lessee. In the event Lessee does not

approve Lessor's Change, Lessee shall provide detailed written reasons for such disapproval, and Lessor shall promptly thereafter resubmit the Change to Lessee, and the process shall be repeated until the Change has been approved, or deemed approved, by Lessee. The Plans and Specifications, with any approved Changes incorporated therein, shall be deemed added to this Lease as Exhibit C. The date Lessor substantially completes construction of the Improvements and Lessee accepts possession of the Improvements in writing is the "Delivery Date".

3.2 On the Delivery Date, Lessor shall donate the portion of the Improvements located within the Public Inflow & Outflow Areas (the "Off-Premises Improvements") to Lessee for the use and benefit of the Sewerage and Water Board of New Orleans ("SWBNO") on the terms and conditions described in the CEA. Lessee hereby grants Lessor, its successors or assigns, an irrevocable and transferable license commencing on the Effective Date and expiring one (1) year after the termination or expiration of this Lease, to enter upon Public Inflow & Outflow Areas for purposes of constructing the Off-Premises Improvements and exercising Lessor's rights and remedies under Section 3.6 and 5.1(b) of this Lease. After the Delivery Date, Lessor shall have no financial obligations associated with the maintenance, repair, and replacement of the Off-Premises Improvements. At all times during the Term after the Delivery Date, Lessee shall, at its sole cost and expense, keep and maintain the Off-Premises Improvements in good working order, condition, and repair, normal wear and tear excepted. In the event Lessee fails to perform its obligations after the expiration of the cure period provided in Section 5.1(b) and Lessor chooses, at its option, to perform Lessee's obligations, Lessee shall be obligated to immediately reimburse Lessor for any expenses Lessor incurs as a result of Lessee's failure to satisfy its obligations under this Section 3.2. Lessor shall be entitled to use City water from fire hydrants located on or adjacent to

Lessor's property free of charge in connection with Lessor's maintenance obligations under this Lease.

3.3 The Improvements located on the Leased Premises, including the Retention Area and the Leased Inflow & Outflow Areas, are referred to collectively herein as the "On-Premises Improvements". At all times during the Term, Lessor shall, at its sole cost and expense, keep the On-Premises Improvements in good working order, condition, and repair, normal wear and tear excepted. In the event Lessor fails to perform its obligations after the expiration of the cure period provided in Section 5.1(b) and Lessee chooses, at its option, to perform Lessor's obligations, Lessor shall be obligated to immediately reimburse Lessee for any expenses Lessee incurs as a result of Lessor's failure to satisfy its obligations under this Section 3.3. Notwithstanding anything to the contrary contained herein, Lessor's aggregate obligation to maintain the On-Premises Improvements in the condition required by this Section 3.3 shall not exceed \$65,000.00 (the "Maintenance Cap") for the first five (5) consecutive Lease Years of the Term (and together with each consecutive period of five Lease Years, each a "Maintenance Cap Period"). Effective upon the first day of the second Maintenance Cap Period and continuing thereafter on the first day of each Maintenance Cap Period during the Term, the Maintenance Cap shall increase by five percent (5%) over the Maintenance Cap for the prior Maintenance Cap Period. If the cost of maintenance exceeds the Maintenance Cap in any given Maintenance Cap Period (the "Maintenance Shortfall"), then Lessor shall be entitled to reimbursement equal to the Maintenance Shortfall from funds under the EDD CEA (as defined in the CEA) on the terms and conditions described in the EDD CEA. If the available funds under the EDD CEA (the "EDD Funds") are not sufficient to cover the applicable Maintenance Shortfall, then Lessor may use the EDD Funds collected in future years to satisfy the applicable Maintenance Shortfall on the terms and conditions described in the EDD

CEA. Lessor shall regularly inspect the condition of the On-Premises Improvements and shall, upon Lessee's advance written request, provide Lessee with a detailed written inspection report regarding the condition of the Improvements, provided, however, Lessor shall have no obligation to provide such written inspection report more often than once during each Maintenance Cap Period. Lessee shall, or shall cause SWBNO to, inspect the condition of the Off-Premises Improvements on an annual basis and shall, upon Lessor's advance written request, provide Lessor with a detailed written inspection report regarding the condition of the Improvements.

3.4 Lessor shall be solely responsible for securing the Retention Area with a lock and for any other security to the On-Premises Improvements as Lessor deems necessary in its discretion. Any and all activities relating to, on, or within any and all areas of the Leased Premises and On-Premises Improvements shall be the sole responsibility of the Lessor.

3.5 Prior to the signing of this Lease, Lessor and Lessee shall each have verified to its satisfaction that the intended use of the Leased Premises and Improvements complies with all applicable zoning laws, regulations, ordinances, and all other city, state, and federal laws.

3.6 Lessee shall surrender the On-Premises Improvements and the Leased Premises to Lessor at the termination of this Lease and Lessee shall cooperate with Lessor's efforts to close the point of connection between the On-Premises Improvements and the Off-Premises Improvements.

3.7 After the Delivery Date, Lessor shall not alter or modify the Improvements without Lessee's prior written approval of plans and specifications for such alterations or modifications, which approval shall not be unreasonably conditioned, delayed or withheld. Notwithstanding the foregoing, alterations in the ordinary course of Lessor's maintenance and repair obligations or in connection with Lessor's rights under Section 3.8 of this Lease shall not require Lessee's approval, provided that any such alterations or modifications do not materially diminish or impair the

capacity or function of the Improvements. All alterations of the Improvements shall be at Lessor's sole cost and expense.

3.8 Lessee agrees and acknowledges that Lessor intends to construct improvements on the surface of the land above the Leased Premises. Provided that none of the following activities will permanently or materially interfere with Lessee's use and enjoyment of the Improvements, it is expressly understood and agreed that Lessor may, at its sole option, and without Lessee's consent, and further without incurring any liability to Lessee and without it constituting an eviction:

- (i) construct new buildings, improvements or other constructions, or alter or remove same, on or above the surface of the land on which the Leased Premises are a part;
- (ii) construct, change and add to the risers, foundations, support columns, plenums, electrical wires, pipes, conduits, and ducts or other structural and nonstructural installations in the Leased Premises where desirable to serve Lessor's buildings, improvements or other constructions or to facilitate the construction, maintenance, repair, replacement, expansion or alteration of the Lessor's buildings, improvements or other constructions;
- (iii) temporarily obstruct or close off the Leased Premises or parts thereof, including the Improvements, and/or block the inflow and outflow of stormwater from the Improvements or other drainage improvements connecting to the Improvements for the purpose of maintenance or repairs, to remodel, construct or expand the Lessor's buildings, improvements or other constructions, or to undertake any other activity permitted under this Lease, including in connection with Lessor's rights under Section 3.3 or under this Section 3.8;
- (iv) grant third parties easements or servitudes within the Leased Inflow & Outflow Areas provided that such easements or servitudes do not permanently or materially interfere with Lessee's use of the Leased Inflow & Outflow Areas;
- (v) drain stormwater from the Leased Premises and Lessor's surrounding land and improvements into the Improvements located on the Leased Premises; and/or
- (vi) alter, modify

(including the elevation of the slab), or replace the slab located above the Retention Area and Lessee hereby acknowledges such slab shall not be part of the Leased Premises. Lessor and its employees, agents and contractors shall have access to the Leased Premises at all times during the Term for the purposes of inspecting the Leased Premises and for the purposes set forth in this Section 3.8.

IV. INSURANCE AND INDEMNITY

4.1 Notwithstanding anything to the contrary in this Article IV, Lessee shall retain the right to “Self-Fund” for any and/or all the insurance coverages as required under this Lease.

4.2 Subject to Section 4.1, Lessee shall purchase and maintain for the duration of the Lease insurance against claims, demands, lawsuits, or actions of any kind for injuries to or death of persons or damages to or destruction of property which may arise from or in connection with the Lessee’s use of the Leased Premises. The cost of such insurance shall be borne solely by the Lessee and shall be subject to the following requirements:

4.2.1. MINIMUM SCOPE AND LIMITS OF INSURANCE

a. Commercial General Liability

Commercial General Liability insurance, including Personal and Advertising Injury Liability, shall have a minimum limit per occurrence of \$1,000,000 and a minimum general annual aggregate of \$2,000,000. The Insurance Services Office (ISO) Commercial General Liability occurrence coverage form CG 00 01 (current form approved for use in Louisiana), or similar acceptable to the Lessor, is to be used in the policy.

b. Intentionally Omitted

c. **Property Insurance**

Upon the Delivery Date, property insurance against all risks of loss to any of the Improvements or Lessee's betterments at full replacement cost with no coinsurance penalty provision.

d. **Umbrella Policy**

An umbrella policy of at least \$10,000,000 per occurrence.

e. **Worker's Compensation**

A policy or policies of worker's compensation insurance in the minimum amount required by law.

If the Lessee maintains broader coverage and/or higher limits than the minimums shown above, the Lessor requires and shall be entitled to the broader coverage and/or the higher limits maintained by the Lessee. Any available insurance proceeds in excess of the specified minimum limits of insurance and coverage shall be available to the Lessor.

4.2.2. DEDUCTIBLES AND SELF-INSURED RETENTIONS

Any deductibles or self-insured retentions must be declared to and accepted by the Lessor. The Lessee shall be solely responsible for all deductibles and self-insured retentions.

4.2.3. OTHER INSURANCE PROVISIONS

The policies are to contain, or be endorsed to contain, the following provisions:

- a. Commercial General Liability & Umbrella Policy. The Lessor, its officers, agents, employees and volunteers and Lessor's mortgagees and ground lessees shall be named as an additional insured on the Lessee's Commercial General Liability Policy and Umbrella Policy as regards negligence of the Lessee and liability arising out of the use of and operations within the Leased Premises by Lessee. ISO Form CG 20 10 (for ongoing work),

or equivalent, is to be used when applicable during construction. ISO Form Endorsement Additional Insured—Owners, Lessees or Contractors—Completed Operations (CG 20 37), or equivalent acceptable to the Lessor, is to be used to provide additional coverage for injury or damage that occurs after the work is completed—work that is included within the “products-completed operations hazard.” ISO Form Additional Insured—Managers or Lessors of Premises (CG 20 11), or equivalent acceptable to the Lessor, is also to be used. The coverage shall contain no special limitations on the scope of protection afforded to the Lessor.

- b. The Lessee’s insurance shall be primary coverage, at least as broad as ISO Form CG 20 01 04 13, as respects the Lessor, its officers, agents, employees and volunteers. Any insurance or self-insurance maintained by the Lessor shall be excess and non-contributory of the Lessee’s insurance.
- c. Lessee and its insurers agree to waive any right of subrogation which any insurer may acquire against the Lessor by virtue of the payment of any loss under insurance required by this contract.
- d. All Coverages
 - i. Each insurance policy required above shall provide that coverage shall not be canceled, except with prior notice to the Lessor of no less than 60 days.
 - ii. The acceptance of the completed work, payment, failure of the Lessor to require proof of compliance, or Lessor’s acceptance of a non-compliant certificate of insurance shall not release the Lessee from the obligations of the insurance requirements or indemnification agreement.

- iii. The insurance companies issuing the policies shall have no recourse against the Lessor for payment of premiums or for assessments under any form of the policies.
 - iv. Any failure of the Lessor to comply with reporting provisions of the policy shall not affect coverage provided to the Lessor, its officers, agents, employees and volunteers.
- d. The obligations for Lessee to procure and maintain insurance shall not be construed to waive or restrict other obligations. It is understood that neither failure to comply nor full compliance with the foregoing insurance requirements shall limit or relieve Lessee from any liability as a result of their activities/operations in conjunction with this Lease.

4.2.4. ACCEPTABILITY OF INSURERS

All required insurance shall be provided by a company or companies lawfully authorized to do business in Louisiana. Insurance is to be placed with insurers licensed and authorized to do business in the State of Louisiana with a current A.M. Best's rating of no less than A:VII, unless otherwise acceptable to the Lessor. If at any time an insurer issuing any such policy does not meet the minimum A.M. Best rating, the Lessee shall obtain a policy with an insurer that meets the A.M. Best rating and shall submit another Certificate of Insurance within 30 days.

4.2.5. VERIFICATION OF COVERAGE

- a. Lessee shall furnish the Lessor with Certificates of Insurance reflecting proof of required coverage. The Certificates for each insurance policy are to be signed by a person authorized by that insurer to bind coverage on its behalf. The Certificates are to be received and approved by the Lessor before work commences and upon any contract renewal or insurance policy renewal thereafter.

- b. The Certificate Holder shall be listed as follows and be delivered via US Mail to:

MERCY PARTNERS, LLC
1000 South Norman C. Francis Parkway
New Orleans, LA 70125

Lessee shall update the information and address for the Certificate Holder upon the Lessor's request.

- c. In addition to the Certificates, Lessee shall submit the declarations page for each insurance policy and copies of all required Additional Insured Endorsements. The Lessor reserves the right to request complete certified copies of all required insurance policies at any time.

4.2.6. INDEMNIFICATION/HOLD HARMLESS AGREEMENT

- a. Lessor agrees to protect, defend, indemnify, save, and hold harmless, Lessee and its officers, directors, officials, agents, servants, employees, advisors, consultants, contractors, subcontractors, volunteers, or other representatives (collectively, the "Lessee Indemnitees"), from and against any and all claims, demands, lawsuits, actions, damages, expenses, and liability for injury or death to any person, including, without limitation, employees, agents, contractors, and invitees of Lessee or employees, agents, contractors, and invitees of the Lessor, or the damage, loss, or destruction of any property, including, without limitation, property of either Lessee or the Lessor, or other loss or damage incurred by Lessor, which may occur, arise out of, or in any way relate to: (i) the acts, omissions, or misconduct of Lessor, its employees, agents, servants, officers, directors, visitors, students, contractors, or subcontractors; (ii) the breach by Lessor of any of its obligations under this Lease; or (iii) the operations within and use of the Leased Premises or the Improvements by Lessor, its employees, agents, servants, officers, directors, visitors, students, contractors, or subcontractors. The obligation to indemnify shall extend to and encompass all costs incurred by Lessee and any Lessee Indemnitee in defending such claim, demand,

lawsuit, action, or liability, including, without limitation, attorney, witness, and expert witness fees, and any other litigation related expenses.

- b. Lessee's obligations pursuant to this Section 4.2.6 will not extend to those claims, demands, suits, or causes of action arising out of the gross negligence or willful misconduct of Lessee and its officers, agents, servants, employees, and volunteers.
- c. Lessor has an immediate and independent obligation to, at Lessee's option: (a) defend Lessee and Lessee Indemnitees from or (b) reimburse Lessee and Lessee Indemnitees for their costs incurred in the defense of any claim, lawsuit, action, damage, expense, or liability that actually or potentially falls within this indemnity, even if: (i) the allegations are or may be groundless, false, or fraudulent; or (ii) Lessor is ultimately absolved from liability.
- d. Intentionally Omitted.

4.3 Subject to Section 4.1, at the end of every five (5) Lease Years there shall be a revaluation of the coverage amount of the comprehensive general liability insurance policy and excess/umbrella liability policy by the Lessor and the Lessee to determine if the limits are adequate. If the Lessor determines that the limits shall be raised, the Lessee shall implement such change within forty-five (45) days after its receipt of the written request from the Lessor.

V. DEFAULT

5.1 Conditions of Default: The following are conditions that constitute default under this Lease:

- a. If Lessee fails to fulfill any monetary obligations of Lessee to Lessor, and Lessee fails to cure such monetary default within ten (10) working days after written notice from Lessor to Lessee of such monetary default.

b. If Lessee or its designee fail to perform any of its other non-monetary obligations (including, without limitation, repair or maintenance of the Off-Premises Improvements) under this Lease when due or called for, and fails to cure such non-monetary default within thirty (30) working days after written notice from the Lessor; provided, however, that (i) if the nature of the non-monetary default is the result of a force majeure occurrence or is otherwise of a nature such that it cannot be fully cured within that thirty (30) day period, Lessee shall have such additional time as is reasonably necessary to cure the default so long as Lessee is proceeding diligently to complete the necessary cure and (ii) if the non-monetary default results in an emergency involving possible injury to property or persons in or around the Leased Premises then no advance notice shall be required for Lessor to exercise its remedies under Section 5.2(f) below.

c. If Lessee shall be adjudged bankrupt, or a receiver be appointed for Lessee's property, or if Lessee's interest in this Lease shall pass by operation of law to any person or legal entity other than Lessee, or on the occurrence of dissolution, financial failure, or insolvency, and such adjudication, appointment, or order is not vacated, dismissed, or set aside within thirty (30) days from its entry.

5.2 Remedies for Default: If any of the conditions of default outlined above in Section 5.1 are found to exist, following the notice and cure rights set above, then the Lessor's remedies are as follows:

- a. Intentionally Omitted.
- b. For all other conditions of default, if Lessee does not cure the default, the Lessor may, after the expiration of the notice and cure periods set forth in this Lease, elect to terminate this Lease immediately and seek all remedies as provided under law and equity. Notwithstanding anything to the contrary in this Lease, Lessee agrees and acknowledges that all rent and other amounts paid by Lessee to Lessor, including, but not limited to prepaid rent, shall be fully earned

upon payment and Lessee shall not be entitled to a refund of any such amounts upon termination of this Lease.

c. Intentionally Omitted.

d. If the Lessor elects to terminate this Lease for failure by Lessee to cure any of the conditions of default or at the expiration of the Term, Lessor shall, at its sole cost and expense, within thirty (30) days of such termination, close the Improvements, including blocking the inflow and outflow of stormwater at the point of connection between the Leased Premises and the Off-Premises Improvements, redirect all stormwater to detention areas located outside of the Leased Premises, and otherwise secure the Leased Premises to prevent further use for the purposes set forth in this Lease, all in a good workman like manner and in accordance with applicable laws. The obligations in this Section 5.2(d) shall survive the expiration or termination of this Lease.

e. If the Lessor at any time by reason of Lessee's default pays any sum or does any act that requires payment of any sum, the sum paid by the Lessor shall be immediately due and owing by Lessee to the Lessor at the time the sum is paid.

f. In the event Lessee fails to perform its obligations under this Lease, and Lessor chooses, at its option, to perform Lessee's obligations, Lessee shall be obligated to immediately reimburse the Lessor for any expenses the Lessor incurs as a result of Lessee's failure to satisfy such obligations.

g. If the Lessor institutes legal proceedings to enforce any of its rights or remedies under this Lease, then the Lessor shall be entitled to a recovery of reasonable attorneys' fees, costs, and other expenses reasonably incurred by way of such action.

h. All rights and remedies provided under this Lease are cumulative and may be pursued singularly, or in any combination, and in any order. Further, Lessor shall have the right to pursue any one or all such remedies that may be provided in law or equity.

i. The failure to enforce any of the terms of this Lease will in no event be deemed a waiver of the right to enforce the terms and provisions at a later time.

VI. ASSIGNMENT

6.1 Except as herein provided, Lessee may not assign, mortgage or encumber this Lease in whole or in part, nor sublet all or any portion of the Leased Premises or Improvements, without the prior written consent of Lessor, which may be granted or withheld in Lessor's sole discretion. Such assignment shall require the assignee to undertake all of Lessee's obligations under this Lease and shall include the Lessor as intervenor.

6.2 The consent by Lessor to any assignment or subletting shall not constitute a waiver of the necessity for such consent to any subsequent assignment or subletting.

6.3 No assignment, under letting, occupancy, or collection shall be deemed acceptance of the assignee, subtenant, or occupant as Lessee. Similarly, no assignment, under letting, occupancy, or collection shall be deemed a release of Lessee from further performance by Lessee of the covenants and requirements of this Lease on the part of Lessee, including, but not limited to the provisions of Sections II and III.

6.4 This prohibition against assignment or subleasing includes those by operation of law, legal process, receivership, bankruptcy, or otherwise, whether voluntary or involuntary.

6.5 The Lessee, by its acceptance hereof, acknowledges that Lessor may mortgage or collaterally assign its interest in and to this Lease and the leasehold estate created hereunder to lenders providing financing to Lessor.

6.6 Notwithstanding anything to the contrary contained in this Lease, any assignment in contravention of this Section shall constitute a default under this Lease and shall be null, void, and unenforceable.

6.7 Lessor may, without the need for prior written consent of Lessee, assign this Lease in connection with the sale, transfer, ground lease or mortgage of the Leased Premises. Furthermore, Lessor may subject the Leased Premises to a condominium regime or remove the Leased Premises from a condominium regime. This Lease shall in all respects be junior and subordinate to any mortgages, ground leases or other matters of record and subject to all of the provisions contained therein. In the event of any conflict between the terms of this Lease and any other matters of record, the provisions of the other matters of record shall prevail. Notwithstanding anything to the contrary in this Section 6.7, and upon payment by Lessee of all of the rent herein provided and the observation and performance of all of the covenants, terms and conditions on Lessee's part to be observed and performed, Lessee shall quietly hold and enjoy the Leased Premises for the Term without hindrance or interruption by Lessor or any other person or persons lawfully or suitably claiming by, through or under Lessor, subject to the terms and conditions of this Lease. This Lease and the rights of Lessee shall, at Lessor's option, be at all times subject and subordinate to any mortgage or deed of trust (as the same may be renewed, replaced, modified, extended or consolidated) hereafter encumbering Lessor's interest in the Leased Premises, provided that any such lender or mortgagee ("Mortgagee") shall execute an agreement in form and substance reasonably acceptable to Lessee agreeing that Lessee's rights under this Lease shall not be disturbed by reason of any foreclosure or other exercise of rights by such Mortgagee so long as Lessee is not in default beyond any applicable notice or curative period. Lessee agrees to attorn to any Mortgagee holding a beneficial interest in a mortgage or deed of trust, purchaser at a

foreclosure sale or grantee of a deed in lieu of foreclosure. Any Mortgagee may at any time elect to cause this Lease to have priority over its mortgage by executing unilaterally an instrument subordinating its mortgage to this Lease, or accepting a mortgage containing a clause providing for such subordination. Lessee shall, within thirty (30) days after Lessor's request, execute, acknowledge and deliver any and all instruments reasonably required by Lessor or Lessor's Mortgagee to ratify or confirm the foregoing.

VII. ESTOPPEL CERTIFICATION

7.1 Either party shall, without charge, and at any time, within thirty (30) days after written request of the other, certify by written instrument duly executed and acknowledged to any mortgagee or purchaser, or proposed mortgagee or proposed purchaser, or any other person, firm, or corporation specified in such request: (a) as to whether this Lease has been supplemented or amended, and if so, the substance and manner of such supplement or amendment; (b) as to the validity of the Lease and that the Lease is in full force and effect; (c) as to the existence of any default hereunder; (d) as to the existence of any offsets, counterclaims, or defenses hereto on the part of such other party; (e) as to the commencement and expiration dates of the terms of this Lease and whether there are any remaining options to extend the Lease; and (f) as to any other matters as may reasonably be so requested. Any such certificate may be relied upon by the party requesting it and any other person, firm, or corporation to whom the same may be exhibited or delivered, and the contents of such certificate shall be binding on the party executing same.

VIII. NOTICE

8.1 All notices, demands, and requests which may or are required to be given by either party to the other shall be in writing. All notices, demands, and requests by the Lessor to Lessee shall

be deemed to have been properly given if served personally on Lessee or if sent by United States Postal Service, registered mail, postage prepaid, addressed as follows:

To Lessee: Director
 Office of Community Development
 1340 Poydras Street, Suite 1000
 New Orleans, Louisiana 70112

and

Director
Department of Public Works
1300 Perdido Street, Suite 6W03
New Orleans, Louisiana 70112

With a Copy to: City Attorney
 1300 Perdido Street, Room 5E03
 New Orleans, Louisiana 70112

And With Copy to: Real Estate Administrator
 Division of Real Estate and Records
 1300 Perdido Street, Room 5W06
 New Orleans, Louisiana 70112

or at such other place as Lessee may from time to time hereafter designate in written notices to the Lessor. All notices, demands, payments, and requests by Lessee to the Lessor shall be deemed to have been properly given or made if served personally on, or if sent by United States Postal Service, registered mail, postage prepaid, addressed as follows:

To the Lessor: 1000 South Norman C. Francis Parkway
 New Orleans, LA 70125
 Attn: Paul Flower

With a copy to: Kevin Leftwich
 Jones Walker, LLP
 201 St. Charles Ave., 50th Floor
 New Orleans, LA 70170

or at such other place as Lessor may from time to time hereafter designate in a written notice to Lessee.

IX. AS-IS CONDITION AND WAIVER OF WARRANTY

9.1 Lessee accepts possession of the Leased Premises as of the Delivery Date “as-is, where-is” and without any warranty whatsoever. Lessee waives any rights or claims against Lessor for damages or losses resulting from (i) defects existing on the Leased Premises as of the Delivery Date, if any, including hazardous materials, or (ii) Lessee’s use of the Lease Premises, including any and all acts or omissions of Lessee, and its and their volunteers, students, vendors, contractors, subcontractors, employees, agents, or invitees. EXCEPT AS EXPRESSLY SET FORTH HEREIN, LESSEE HEREBY WAIVES ALL EXPRESS OR IMPLIED REPRESENTATIONS OR WARRANTIES ON THE PART OF LESSOR, INCLUDING, BUT NOT LIMITED TO, ALL WARRANTIES THAT THE LEASED PREMISES ARE SUITABLE FOR THE USED PERMITTED HEREIN OR ARE FREE FROM VICES, DEFECTS, OR DEFICIENCIES, WHETHER HIDDEN OR APPARENT, AND IF THE LEASED PREMISES ARE LOCATED IN LOUISIANA, ALL WARRANTIES UNDER LA. CIV. CODE ARTS. 2682(2), 2684, 2691, OR 2696-2699, OR ANY OTHER PROVISION OF LAW.

BY INITIALING BELOW, LESSEE EXPRESSLY ACKNOWLEDGES THAT LESSEE HAS READ THIS WAIVER, HAS HAD IT BROUGHT TO LESSEE’S ATTENTION, HAS HAD THE OPPORTUNITY TO DISCUSS THIS WAIVER WITH ITS ATTORNEY, AND THAT LESSEE UNDERSTANDS AND ACCEPTS ITS TERMS.

Initials of Lessee’s Authorized Representative

X. MANDATORY CITY LEASE PROVISIONS

10.1 Inspector General Statement: This section is intended to meet the statement requirements regarding the City of New Orleans Office of Inspector General, as codified in the Code of the City

of New Orleans Chapter 2, Article XIII, Section 2-1120 (20), as per Ordinance No. 24395 M.C.S. Lessor will abide by all provisions of City Code Section 2-1120, including but not limited to City Code Section 2-1120 (12), which requires the Lessor to provide the Office of Inspector General with documents and information as requested as related to this Lease. Failure to comply with such requests shall constitute a material breach of this Lease. In signing this Lease, the Lessor agrees that it is subject to the jurisdiction of the Orleans Parish Civil District Court for purposes of challenging a subpoena. Lessor further hereby expressly and explicitly agrees to cooperate with the Inspector General in any investigation, audit, inspection, performance review, or hearing pursuant to said chapter.

10.2 Convicted Felon Statement: The Lessor complies with §2-8(c) of the Code of the City and no principal or official of the Lessor has, within the preceding five years, pled guilty to or been convicted of a felony under state or federal statutes for embezzlement, theft of public records, bribery, falsification or destruction of public records, and/or receiving stolen property.

10.3 Non-Solicitation Statement: Lessor has not employed or retained any company or person, other than a bona fide employee working solely for him, to solicit or secure the subject contract. Lessor has not paid or agreed to pay any person, other than a bona fide employee working for him, any fee, commission, percentage, gift, or any other consideration contingent upon or resulting from the subject contract.

XI. MISCELLANEOUS

11.1 This Lease and the performance thereof shall be governed, interpreted, construed, and regulated by the laws, ordinances, and codes of the City, the State of Louisiana, and the United States Federal Government.

11.2 Lessee shall pay the cost of promulgation of the Ordinance authorizing this Lease.

11.3 The covenants and agreements contained in this Lease shall bind and inure to the benefit of the parties hereto and their respective successors and assigns.

11.4 The Leased Premises and Improvements described above may not interfere with any servitude for public utility facilities for private and public utility companies and said utility companies shall have the right of ingress and egress to and around the Improvements with vehicles and equipment at any and all times.

11.5 Intentionally Omitted.

11.6 Lessee shall pay all real estate taxes and assessments imposed upon the Leased Premises, if imposed by any governmental body.

11.7 In the event any one or more of the provisions contained in this agreement shall for any reason be held to be invalid, illegal, or unenforceable in any respect, such invalidity, illegality, or unenforceability shall not affect any other provision, and this agreement shall be construed as if such invalid, illegal, or unenforceable provision had never been contained herein.

11.8 Both parties acknowledge that public and private utilities will be allowed to cross the Leased Premises, if needed, to provide their appropriate services to property within the area.

11.9 Lessor and Lessee shall comply with all applicable zoning laws, ordinances, and regulations of the City of New Orleans, as well as all applicable State or Federal laws, codes, and regulations.

11.10 Because of the nature and complexity of the obligations to be undertaken under this Lease, the parties agree that nonbinding mediation shall serve as the initial method for resolving any disputes related to or arising out of the obligations contemplated under this Lease (each, a "Dispute"). Either party may initiate mediation by written notice to the other party identifying the Dispute and proposing at least three qualified, neutral mediators. The parties shall jointly select a

mediator within 15 days of the notice, and the mediation shall be held within 45 days thereafter, unless the parties agree in writing to extend these periods. The mediation shall take place in New Orleans, Louisiana, and the parties shall share the mediator's fees and expenses equally, provided that each party shall bear its own attorneys' fees and costs. Completion of one mediation session (lasting at least one full day, unless earlier terminated by the mediator) or 60 days having passed after the mediator's appointment, whichever occurs first, shall satisfy this requirement and shall be a condition precedent to the initiation of any lawsuit arising out of the same Dispute. In the event any dispute may not be reasonably resolved through mediation, the parties will consent to the jurisdiction of the State Civil Courts of the Parish of Orleans and will formally waive any pleas of jurisdiction on account of residence elsewhere.

[The remainder of this page is intentionally left blank]

(Signatures and Exhibits contained on the following pages)

THUS DONE AND PASSED in multiple originals on the _____ day of _____, 2026, in the presence of the undersigned competent witnesses, who hereunto sign their names with the said Appearers, and me Notary, after due reading of the whole.

WITNESSES:

LESSOR: **MERCY PARTNERS, LLC**

Signature

Print Name:

BY: _____,

Print Name: Paul Flower

Its: Manager, Authorized Representative

Signature

Print Name:

NOTARY PUBLIC

THUS DONE AND PASSED in multiple originals on the ____ day of _____, 2026, in the presence of the undersigned competent witnesses, who hereunto sign their names with the said Appearers, and me Notary, after due reading of the whole.

WITNESSES:

LESSEE: **CITY OF NEW ORLEANS**

Signature

Print Name:

Signature

Print Name:

BY: _____,

HELENA MORENO, MAYOR
CITY OF NEW ORLEANS

APPROVED AS TO FORM AND
LEGALITY BY:

NOTARY

CITY OF NEW ORLEANS, CITY COUNCIL

BY: _____
CITY COUNCIL PRESIDENT

[EXHIBITS A-C CONTAINED ON THE FOLLOWING PAGES]

[Lessee's Signature Page]

Exhibit A

Legal Description of the Retention Area

A CERTAIN PORTION OF GROUND together with all the rights, ways, privileges, servitudes and appurtenances thereunto belonging or in anywise appertaining, situated in the Second Municipal District of the City of New Orleans, Square 476 A, bounded by North Norman C. Francis Parkway, Bienville Street, North Cortez Street and Conti Street, designated as Plan of Mercy Hospital Basement as shown on a plan by the Office of Gandolfo Kuhn LLC, dated January 26, 2026, drawing number T-258-4; and is more particularly described as follows:

Commence at the intersection of the northerly line of North Norman C. Francis Parkway and the easterly line of Bienville Street;

Thence in a northerly direction along the easterly line of Bienville Street a distance of 255 feet 0 inches 2 eighths to a point;

Thence N37°12'45"E a distance of 8 feet 0 inches 7 eighths to the Point Of Beginning;

Thence N52°48'36"W a distance of 29 feet 11 inches 5 eighths to a point;

Thence N34°27'01"E a distance of 0 feet 11 inches 4 eighths to a point;

Thence N07°23'49"W a distance of 10 feet 1 inch 1 eighth to a point;

Thence S82°07'24"W a distance of 8 feet 3 inches 3 eighths to a point;

Thence N07°43'11"W a distance of 90 feet 9 inches 7 eighths to a point;

Thence S81°48'38"W a distance of 35 feet 4 inches 3 eighths to a point;

Thence S08°11'22"E a distance of 37 feet 7 inches 4 eighths to a point;

Thence S83°11'16"W a distance of 24 feet 8 inches 0 eighths to a point;

Thence N08°06'29"W a distance of 30 feet 5 inches 5 eighths to a point of curvature;

Thence along the arc of a curve to the left having a radius of 23 feet 11 inches 5 eighths an arc length of 32 feet 11 inches 4 eighths, a chord bearing of N57°19'44"W a chord distance of 30 feet 5 inches 0 eighths to a point of tangency;

Thence S83°00'48"W a distance of 29 feet 4 inches 3 eighths to a point;

Thence N07°45'27"W a distance of 23 feet 5 inches 1 eighth to a point;

Thence N81°21'19"E a distance of 40 feet 11 inches 5 eighths to a point;

Thence N07°30'33"W a distance of 40 feet 1 inch 5 eighths to a point;

Thence N82°17'18"E a distance of 82 feet 2 inches 1 eighth to a point;

Thence N07°40'43"W a distance of 5 feet 8 inches 3 eighths to a point;

Thence N82°19'17"E a distance of 53 feet 10 inches 4 eighths to a point;

Thence N07°40'43"W a distance of 9 feet 3 inches 5 eighths to a point;

Thence N82°19'17"E a distance of 42 feet 5 inches 5 eighths to a point;

Thence S07°40'43"E a distance of 9 feet 9 inches 3 eighths to a point;

Thence N82°19'42"E a distance of 30 feet 5 inches 5 eighths to a point;

Thence S07°42'21"E a distance of 92 feet 2 inches 7 eighths to a point;

Thence N82°18'59"E a distance of 42 feet 10 inches 0 eighths to a point;

Thence N07°44'17"W a distance of 92 feet 1 inch 4 eighths to a point;

Thence N82°09'57"E a distance of 46 feet 1 inch 0 eighths to a point;

Thence S07°41'19"E a distance of 27 feet 4 inches 0 eighths to a point;

Thence N82°18'41"E a distance of 27 feet 0 inches 1 eighth to a point;

Thence S52°48'34"E a distance of 89 feet 3 inches 0 eighths to a point;

Thence S07°40'25"E a distance of 11 feet 4 inches 5 eighths to a point;
Thence N82°19'17"E a distance of 6 feet 10 inches 2 eighths to a point;
Thence S07°40'43"E a distance of 29 feet 1 inch 3 eighths to a point;
Thence N82°19'17"E a distance of 14 feet 11 inches 1 eighth to a point;
Thence S07°40'43"E a distance of 4 feet 8 inches 4 eighths to a point;
Thence N82°02'46"E a distance of 33 feet 0 inches 5 eighths to a point;
Thence S07°43'32"E a distance of 63 feet 0 inches 0 eighths to a point;
Thence S81°54'35"W a distance of 4 feet 0 inches 2 eighths to a point;
Thence S07°56'38"E a distance of 16 feet 4 inches 0 eighths to a point;
Thence S82°15'59"W a distance of 93 feet 5 inches 1 eighth to a point;
Thence S01°50'29"E a distance of 1 foot 11 inches 5 eighths to a point;
Thence S82°15'11"W a distance of 21 feet 4 inches 0 eighths to a point;
Thence S07°33'36"E a distance of 11 feet 9 inches 5 eighths to a point;
Thence S82°10'26"W a distance of 1 foot 7 inches 0 eighths to a point;
Thence S07°49'34"E a distance of 34 feet 8 inches 2 eighths to a point;
Thence S18°29'37"W a distance of 23 feet 9 inches 4 eighths to a point of intersection;
Thence along the arc of a curve to the left having a radius of 107 feet 9 inches 0 eighths
an arc length of 76 feet 1 inch 2 eighths, a chord bearing of S82°08'45"W a chord
distance of 74 feet 6 inches 3 eighths to a point of intersection;
Thence N33°38'51"W a distance of 22 feet 9 inches 2 eighths to a point;
Thence N07°42'51"W a distance of 35 feet 3 inches 0 eighths to a point;
Thence S84°37'35"W a distance of 1 foot 6 inches 1 eighth to a point;
Thence N07°42'57"W a distance of 12 feet 0 inches 3 eighths to a point;
Thence S82°28'36"W a distance of 21 feet 3 inches 5 eighths to a point;
Thence N07°37'52"W a distance of 1 foot 11 inches 5 eighths to a point;
Thence S82°19'17"W a distance of 93 feet 8 inches 0 eighths to a point;
Thence N08°02'52"W a distance of 10 feet 10 inches 0 eighths to a point;
Thence S80°19'49"W a distance of 10 feet 0 inches 0 eighths to a point;
Thence S37°11'24"W a distance of 1 foot 0 inches 0 eighths to the Point Of Beginning;
And containing 77,374 Square Feet or 1.7763 acres.

Exhibit B

Legal Description of the Leased Inflow & Outflow Areas

A CERTAIN PORTION OF GROUND together with all the rights, ways, privileges, servitudes and appurtenances thereunto belonging or in anywise appertaining, situated in the Second Municipal District of the City of New Orleans, Square 476 A, bounded by North Norman C. Francis Parkway, Bienville Street, North Cortez Street and Conti Street, designated as Inlet Servitude as shown on a plan of resubdivision by the Office of Gandolfo Kuhn LLC, dated September 10, 2025, last revised February 11, 2026 drawing number T-258-2; and is more particularly described as follows:

Commence at the intersection of the northerly line of North Norman C. Francis Parkway and the easterly line of Bienville Street;
Thence in a northerly direction along the easterly line of Bienville Street a distance of 371 feet to the Point Of Beginning;
Thence continue along said line a distance of 11 feet 7 inches 0 eighths to a point;
Thence along an angle to the left of 59°41'24" a distance of 69 feet 6 inches 0 eighths to a point;
Thence along an angle to the left of 75°14'32" a distance of 10 feet 4 inches 0 eighth to a point;
Thence along an angle to the left of 104°45'28" a distance of 61 feet to the Point Of Beginning, and containing 653 Square Feet;

AND

A CERTAIN PORTION OF GROUND together with all the rights, ways, privileges, servitudes and appurtenances thereunto belonging or in anywise appertaining, situated in the Second Municipal District of the City of New Orleans, Square 476 A, bounded by North Norman C. Francis Parkway, Bienville Street, North Cortez Street and Conti Street, designated as Outlet Servitude as shown on a plan of resubdivision by the Office of Gandolfo Kuhn LLC, dated September 10, 2025, last revised February 11, 2026 drawing number T-258-2; and is more particularly described as follows:

Commence at the intersection of the northerly line of North Norman C. Francis Parkway and the westerly line of Conti Street;
Thence in a northerly direction along the westerly line of Conti Street a distance of 46 feet 10 inches 0 eighths to the Point Of Beginning;
Thence continue along said line a distance of 4 feet to a point;
Thence along an angle to the right of 90° a distance of 12 feet to a point;
Thence along an angle to the right of 135°01'34" a distance of 5 feet 8 inches 0 eights to a point;
Thence along an angle to the right of 44°58'26" a distance of 16 feet to the Point Of Beginning, and containing 56 Square Feet;

Exhibit C

Plans and Specifications for the Improvements

See attached.

ACT OF DONATION	*	UNITED STATES OF AMERICA
	*	
BY	*	STATE OF LOUISIANA
	*	
MERCY PARTNERS, LLC	*	PARISH OF ORLEANS
	*	
TO	*	AND
	*	
THE CITY OF NEW ORLEANS	*	STATE OF LOUISIANA
	*	
	*	PARISH OF ORLEANS

1. Introduction and Parties

1.1 Be it known, that on this ____ day of _____, 2026, before the undersigned Notary Public, duly commissioned and qualified in and for the State of Louisiana, Parish of Orleans, and in the presence of the undersigned competent witnesses, personally came and appeared:

MERCY PARTNERS, LLC (the "**Donor**"), a Louisiana limited liability company, whose mailing address is 1000 South Norman C. Francis Parkway, New Orleans, Louisiana 70125, appearing herein through _____, its _____, duly authorized pursuant to a _____ of its _____, a [**certified/original**] copy of which is attached hereto as **Exhibit A**.

1.2 Be it known, that on this ____ day of _____, 2026, before the undersigned Notary Public, duly commissioned and qualified in and for the State of Louisiana, Parish of Orleans, and in the presence of the undersigned competent witnesses, personally came and appeared:

THE CITY OF NEW ORLEANS (the "**Donee**"), a municipal corporation created by the laws of the State of Louisiana, appearing herein through the Mayor of the City of New Orleans, under and by virtue of an ordinance of the City Council of New Orleans, a copy of which is attached hereto as **Exhibit B**.

1.3 The parties, after being duly sworn, declared as follows.

1.4 Although this Act of Donation (this "**Donation**") is executed on the dates set forth above, it is intended by the parties to be effective as of [____], 2026 (the "**Effective Date**").

2. Donation

2.1 The Donor declares that it does by these presents donate, grant, bargain, convey, transfer, assign, set over, abandon and deliver unto the Donee, which accepts for itself and its successors and assigns, and acknowledges due delivery and possession thereof, all of Donor's rights, title and interest in and to the following-described property (the "**Property**"):

**[INSERT DESCRIPTION OF PUBLIC INFLOW AND
OUTFLOW INFRASTRUCTURE]**

2.2 To have and to hold the Property unto the Donee for itself and its successors and assigns forever.

2.3 The parties hereby acknowledge that Donor is donating the Property to Donee for the use and benefit of the Sewerage and Water Board of New Orleans in consideration of the parties' respective rights and obligations pursuant to the Cooperative Endeavor Agreement dated effective as of [____], 2026 and the Lease of Land dated effective as of [____], 2026.

2.4 Donor warrants that there are no mortgages, liens, or encumbrances of any kind against the Property.

2.5 Except as otherwise expressly provided herein, this Donation is made "as is, where is" and without any warranty of title, except that Donor will warrant title to the Property only against Donor's own acts and the acts of anyone claiming by, through, or under Donor. This Donation is made with full substitution and subrogation in and to all rights and actions in warranty that the Donor has or may have against previous owners and vendors of the Property.

3. Acceptance by Donee

3.1 The Donee accepts the donation of the Property as of the Effective Date.

4. Miscellaneous

4.1 The Donor hereby waives any vendor's lien or right of rescission that it has or may have as a result of the transfers made by this Donation.

4.2 All the agreements and stipulations herein contained and all the obligations herein assumed shall inure to the benefit of and be binding upon the heirs, successors, and assigns of the respective parties hereto.

4.3 This Donation shall be governed by and construed in accordance with the laws of the State of Louisiana.

4.4 The parties agree to cooperate with one another to execute such documents and take such actions as one another may reasonably request to effectuate the intent of this Donation.

4.5 This Donation may be executed in multiple counterparts, each of which shall be an original, and all of which shall together constitute one and the same instrument.

[Signatures on following pages]

5. Closing and Signatures

5.1 Thus done and passed in New Orleans, Louisiana, on the date set forth above, but effective as of the Effective Date, in the presence of the undersigned competent witnesses, who hereunto sign their names with the Donor and me, notary, after due reading of the whole.

WITNESSES:

Print Name: _____

Print Name: _____

DONOR:

Mercy Partners, LLC

By: _____
Name: _____
Title: _____

Notary Public
Print Name: _____
Notary I.D./Bar No. (As Applicable): _____

Parish/County, _____
My commission expires: _____

5.2 Thus done and passed in New Orleans, Louisiana, on the date set forth above, but effective as of the Effective Date, in the presence of the undersigned competent witnesses, who hereunto sign their names with the Donee and me, notary, after due reading of the whole.

WITNESSES:

Print Name: _____

Print Name: _____

DONEE:

The City of New Orleans

By: _____
Helena Moreno, Mayor

APPROVED AS TO FORM AND LEGALITY

City of New Orleans Law Department

Notary Public
Print Name: _____
Notary I.D./Bar No. (As Applicable): _____

Parish/County, _____
My commission expires: _____

Exhibits:

- A - Donor Resolutions
- B - Donee Ordinance

EXHIBIT A
Donor Resolutions

See attached.

EXHIBIT B

Donee Ordinance



See attached.

Name of person responsible for routing: Andrew Bagnato Ext. 8-4939

**CHECK SHEET TO BE USED FOR
CLEARING ORDINANCES, MOTIONS, AND RESOLUTIONS
BEFORE SUBMISSION TO COUNCIL CLERK**

The originating agency shall attach a copy of each proposed ordinance, motion, or resolution to the check sheet for processing in the sequence indicated after preparing a synopsis. The detailed memorandum of explanation shall also be attached to this check sheet.

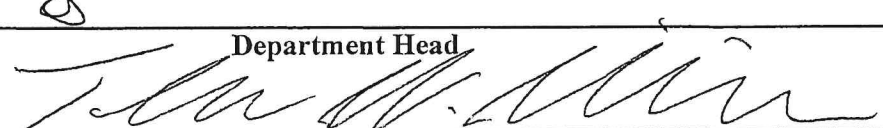
SYNOPSIS OF DOCUMENT: AN ORDINANCE authorizing the Mayor of the City of New Orleans to
enter a Cooperative Endeavor Agreement with Mercy Partners, LLC to fund, design, and construct a
stormwater retention and drainage infrastructure project at the former Lindy Boggs site, including demolition
and integration with the City's drainage system, using proceeds from voter-approved infrastructure and
drainage bonds.

- 1. 8 Department Head

- 2. Department of Law

- 3. Chief Administrative Officer

- 4. Director of Council Relations
- 5. Initials of Sponsoring Council Member

COUNCIL ACTION

Council Members Present: _____

Absent: _____

AMENDMENTS:

FINAL ADOPTION:

7. _____
Reviewed by the Chief Administrative Officer after adoption by the City Council and prior to the Mayor's signature.



LEGISLATIVE SUMMARY

TO ACCOMPANY ORDINANCES

BEFORE SUBMISSION TO CLERK OF COUNCIL

Requesting Department or Agency: _____

Name of Contact Person: _____

Telephone Number: _____

Email Address: _____

Initials of Sponsoring Councilmember(s): _____

DETAILED SYNOPSIS OF THE ORDINANCE

Please generally describe the purpose, intent, and effect of the proposed ordinance.



LEGISLATIVE SUMMARY

If the Ordinance is to effectuate a contract, CEA, or other similar agreement (hereafter contract), please provide the following additional information.

If this section is not applicable, please check this box.

The parties involved:

The obligations, expectations, and deliverables of the parties involved:

Any fiscal implications for the City with the contract:

The public purpose and need for the contract:

The duration of the contract:



LEGISLATIVE SUMMARY

If the Ordinance is to effectuate an amendment to the Codes of the City of New Orleans, please provide the following additional information.

If this section is not applicable, please check this box.

The existing provision(s) of the Code being proposed for amendment:

The general content/requirements of the existing Code provision:

How the proposed ordinance will alter the existing Code provision(s):

Why these changes are needed:

REQUESTED ADOPTION DATE: _____

Reference: Council Rule 41 & City Code Section 2-813